

INDEX

PCH-10 _____	page	3
PCH-25 _____	page	3
PCH-25/38 _____	page	4
PCH-26 _____	page	4
PCH/M-28 _____	page	5
PCH/M-35 _____	page	6
PCH/M-75 _____	page	7
PCH/M-76 _____	page	8
PCH/M-100XL _____	page	9
PCH/M-40 _____	page	10
PCH/M-60 _____	page	11
PCH/M-80 _____	page	12
PCH/M-120 _____	page	13
PCH/M-70 _____	page	14
PCH/M-140 _____	page	15
PCH-145 _____	page	16
PCM-145 _____	page	17
PCH/M-150 _____	page	18
Maximizer 300 _____	page	19 to 21
PCH-20 _____	page	22
PCH-30 _____	page	22
PCH-50 _____	page	22
PCH/M-100 _____	page	23
PCH/M-51 _____	page	24
PCH/M-52 _____	page	25
PCH-52P _____	page	26
PCH-53P _____	page	26
PCH/M-53 _____	page	27
PCH/M-4B(T) _____	page	28
PCH/M-6B _____	page	29
M-200 _____	page	30

ACCESSORIES

CIRCLE CUTTING ATTACHMENTS _____	page	31
----------------------------------	------------	----

AMPROCORP U.S.A., INC.

Website: <http://WWW.amprocorpusa.com> E-mail: info@amprocorpusa.com

UNIT/TORCH COMPARISON FOR THERMAL DYNAMICS CUTTING SYSTEMS

UNIT	TORCH	UNIT	TORCH
4Xi	PCH/M51	Pak-1250XR	PCH/M52
6Xi	PCH/M51	Pak-1250XR	PCH52P
CC-65	M-200	Pak-15XC	PCH/M-150
CC-66	M-200	Pak-15XC W/Max 300 retrofit	PCM/145
Cougar 125	PCH-10	Pak-2XT	PCH20
Cut Master 80XL	PCH/M75	Pak-3	PCH30
Drag-Gun	PCH-10	Pak-3XR	PCH/M51
Drag-Gun 38	PCH-25/38	Pak-44	PCH/M6B
Dynapak 110	PCH20	Pak-45	PCH/M6B
Econopak 100	PCH/M76	Pak-5	PCH50
Econopak 25	PCH-25	Pak-5 (Mech)	PCH/M4B(T)
Econopak 50	PCH-26	Pak-5XR Dual Gas	PCH/M52
Merlin 1000	Maximizer 300	Pak-5XT	PCH/M51
Merlin 3000	PCM/145	Pak-625XR	PCH/M75
Merlin 3000	Maximizer 300	Pak-625XR	PCH/M51
Merlin 6000	Maximizer 300	Pak-625XR Dual Gas	PCH/M52
Merlin 6000GST	Maximizer 300	Pak-6XR	PCH/M51
Pak Master 100	PCH53P Pak	Pak-6XR Dual Gas	PCH/M52
Master 100	PCH/M53	Pak-750XR	PCH/M51
Pak Master 100XL	PCH/M100XL	Pak-750XR Dual Gas	PCH/M52
Pak Master 100XL Plus	PCH/M80	Pak-7XR	PCH/M51
Pak Master 150XL	PCH/M120	Pak-7XR Dual Gas	PCH/M52
Pak Master 25	PCH-25 Pak	Pak-8XR	PCH/M52
Master 38XL	PCH-25/38	Pak-Master 50XL	PCH/M-28
Pak Master 50XL Plus	PCH/M40	Pak Master 50	PCH/M35
Pak Master 75	PCH/M75	Stak Pak	PCH/M35
Pak Master 75XL	PCH/M75	Stak Pak	PCH/M70
Pak Master 75XL Plus	PCH/M60	Stak Pak	PCH/M140
Pak-10	PCH/M4B(T)	Stak Pak	PCH/M145
Pak-1000XR	PCH/M52	TA-500	M-200
Pak-10XR	PCH/M100	TAC-500	M-200
Pak-10XR	PCH/M52	TD750	PCM/145
Pak-10XR (Mech)	PCH/M4B(T)		

PCH-10 Drag-Gun, Cougar 125

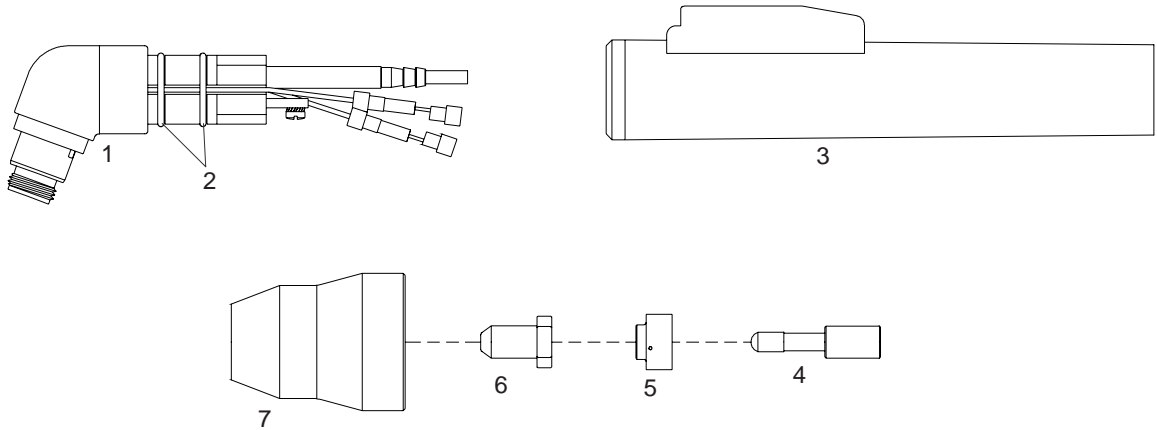

Item	Ref.	Code	Description
N/S	2-1020	07001	Hand torch complete with 20' (6 mts) cable
1	9-0016	07034	70° Torch head
2	8-0533	07100.53	O-Ring (20 pcs.)
3	9-0019E	07103	Handgrip complete with microswitch
4	9-6006	52519/D	Electrode - Hf
5	9-6007	60050	Gas Distributor
6	9-6099	51282	Tip - Air
7	9-6003	60347	Shield Cup
N/S		07002	Air and power cable 20' (6 mts)

* CIRCLE CUTTING ATTACHMENT : See page#31

PCH-25 Econopak 25, Pak Master 25

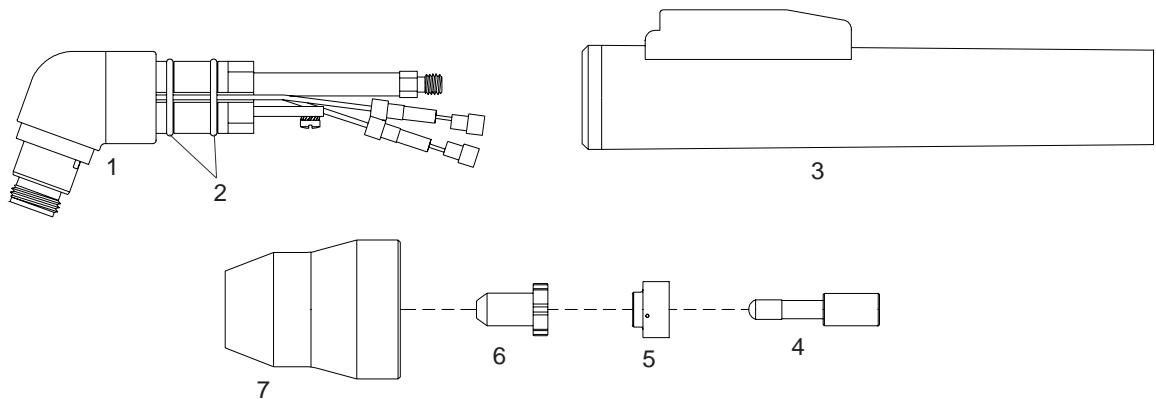

Item	Ref.	Code	Description
N/S	2-0250	07003	Hand torch complete with 12.5' (3.8 mts) cable
N/S	2-0251	07005	Hand torch complete with 25' (7.5 mts) cable
1	9-5807	07035	70° Torch head
2	8-0533	07100.53	O-Ring (20 pcs.)
3	9-6282E	07103	Handgrip complete with microswitch
4	9-6006	52519/D	Electrode - Hf
5	9-6007	60050	Gas Distributor
6	9-4476	51286	Tip - Air
7	9-6003	60347	Shield Cup
N/S	4-6067	07004	Air and power cable 12.5' (3.8 mts) - Hand torch
N/S	4-6068	07006	Air and power cable 25' (7.5 mts) - Hand torch

* CIRCLE CUTTING ATTACHMENT : See page#31

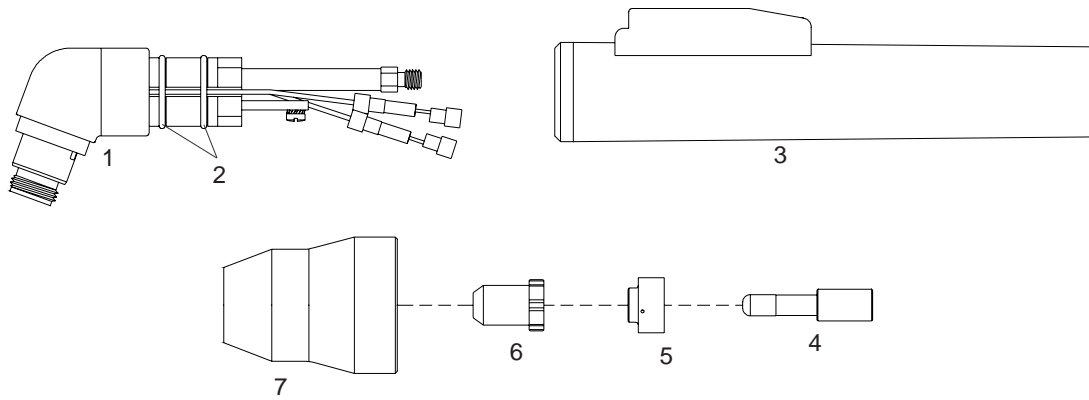
PCH-25/38 Pak Master 38XL, Drag-Gun 38

Item	Ref.	Code	Description
N/S	2-0380	07003	Hand torch complete with 12,5' (3.8 mts)
N/S	2-0381	07005	Hand torch complete with 25' (7.5 mts)
1	9-5807	07035	70° Torch head
2	8-0533	07100.53	O-Ring (20 pcs.)
3	9-6282E	07103	Handgrip complete with microswitch
4	9-6506	52523/D	Electrode - Hf
5	9-6507	60051	Gas Distributor
6	9-6501	51289	Tip - Air
7	9-6003	60347	Shield Cup
N/S	4-6067	07004	Air and power cable 12.5' (3.8 mts) - Hand torch
N/S	4-6068	07006	Air and power cable 25' (7.5 mts) - Hand torch

* CIRCLE CUTTING ATTACHMENT : Seepage#31

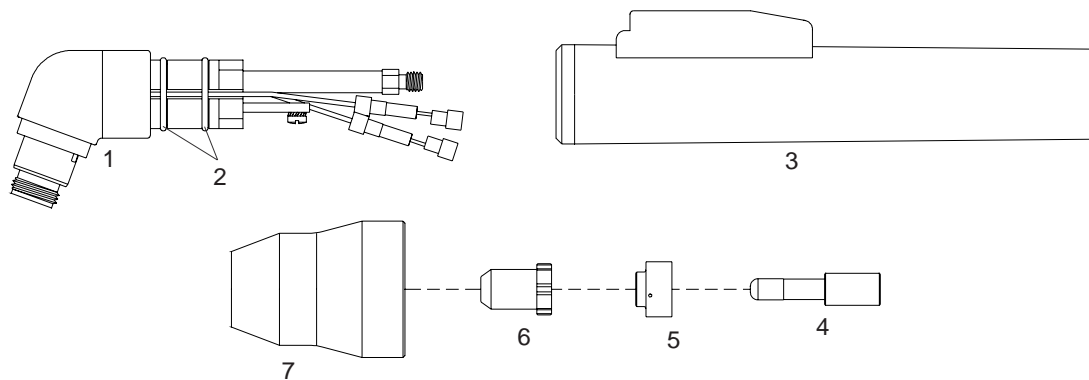
PCH-26 Econopak 50

Item	Ref.	Code	Description
N/S	2-3501	07011	Hand torch complete with 12,5' (3.8 mts)
N/S	2-3511	07012	Hand torch complete with 25' (7.5 mts)
1	9-5807	07035	70° Torch head
2	8-0533	07100.53	O-Ring (20 pcs.)
3	9-6282E	07103	Handgrip complete with microswitch
4	9-6506	52523/D	Electrode - Hf
5	9-6507	60051	Gas Distributor
6	9-6501	51289	Tip - Air
7	9-6003	60347	Shield Cup
N/S	4-6071	07013	Air and power cable 12.5' (3.8 mts) - Hand torch
N/S	4-6072	07014	Air and power cable 25' (7.5 mts) - Hand torch

* CIRCLE CUTTING ATTACHMENT : Seepage#31

PCH/M-28 Pak Master 50XL

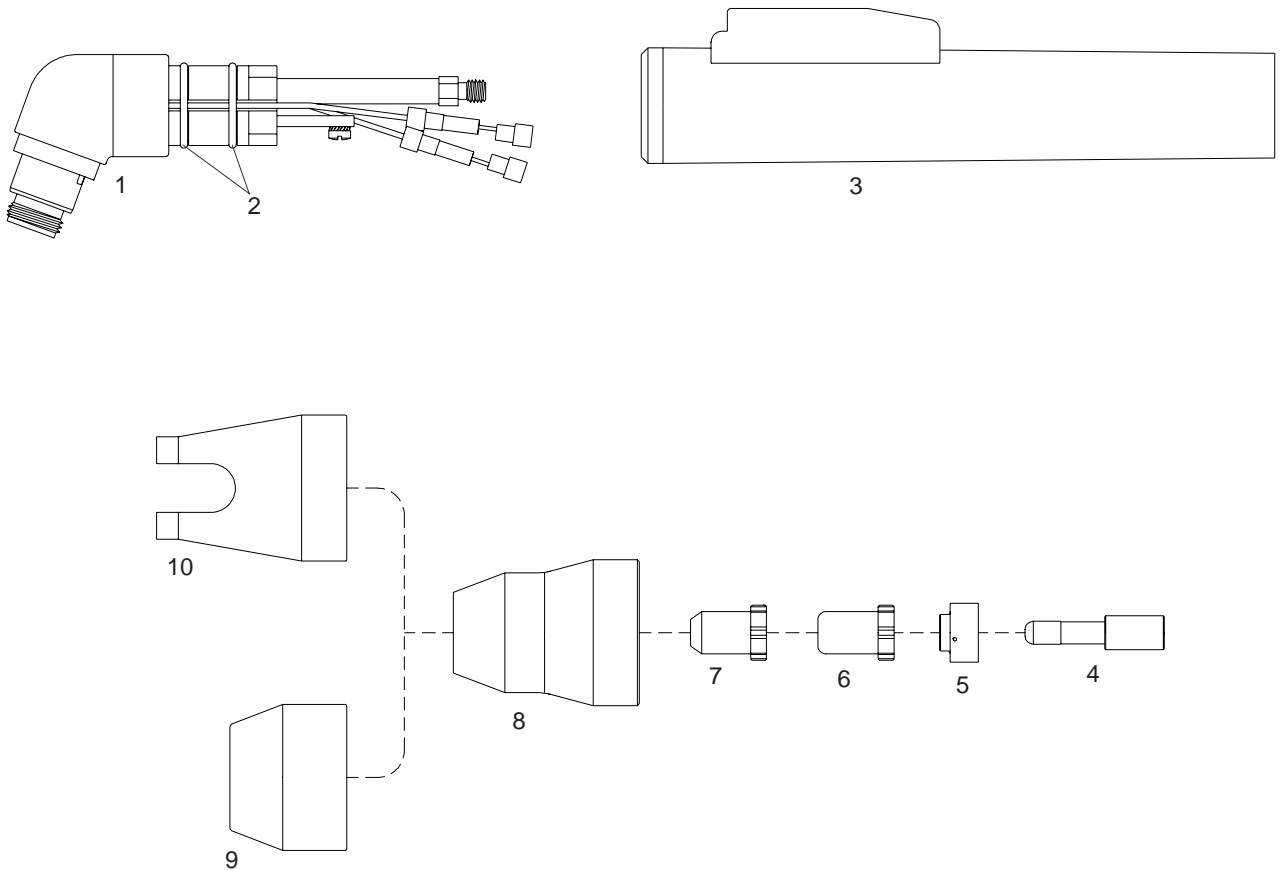

Item	Ref.	Code	Description
N/S	2-5801	07020	Hand torch complete with 25' (7.5 mts) cable
N/S	2-5802	07030	Hand torch complete with 50' (15 mts) cable
1	9-5807	07035	70° Torch head
2	8-0533	07100.53	O-Ring (20 pcs.)
3	9-6291E	07103	Handgrip complete with microswitch
4	9-6506	52523/D	Electrode - Hf (long life)
5	9-6507	60051	Gas Distributor (long life)
6	9-6500	51288	Tip - Standoff (long life)
7	9-6501	51289	Tip - Drag (long life)
8	9-6003	60347	Shield Cup - Std
9	9-6503	60339	Shield Cup - Maximum Life (requires 60347)
10	9-6004	60343	Shield Cup - Crown (requires 60347)
N/S	4-2995	07021	Air and power cable 25' (7.5 mts) - Hand torch
N/S	4-2996	07031	Air and power cable 50' (15 mts) - Hand torch

* CIRCLE CUTTING ATTACHMENT : See page#31

PCH/M-35 Pak Master 50, Stak Pak

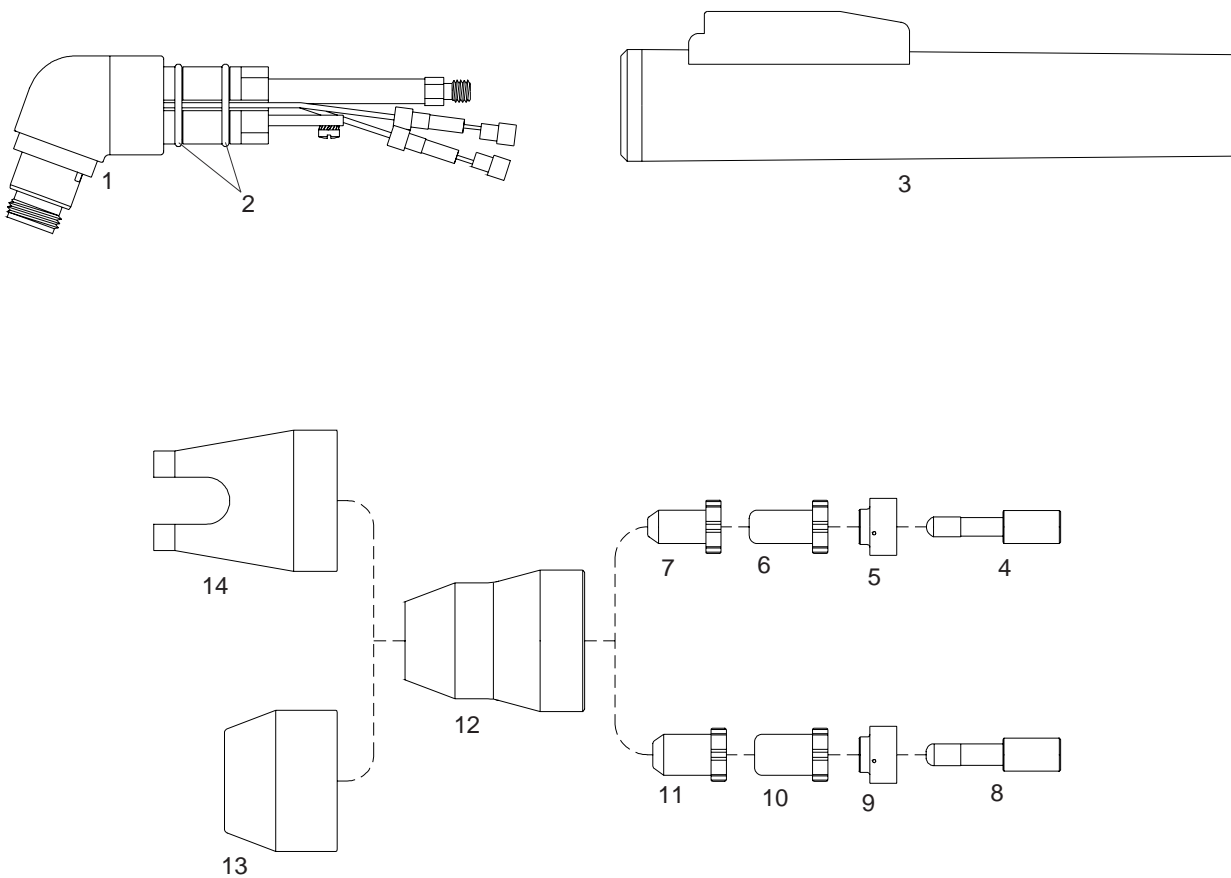

Item	Ref.	Code	Description
1	9-5807	07035	70° Torch head
2	8-0533	07100.53	O-Ring (20 pcs.)
3	8-4305E	07103	Handgrip complete with microswitch
4	9-6006	52519/D	Electrode - Hf
5	9-6007	60050	Gas Distributor
6	9-6000	51290	Tip - 35 Amp. Air
	9-6002	51292	Tip - Gouging - Groove Air
7	9-6001	51291	Tip - Drag Cut Air
8	9-6506	52523/D	Electrode - Hf (long life)
9	9-6507	60051	Gas Distributor (long life)
10	9-6500	51288	Tip - Standoff (long life)
11	9-6501	51289	Tip - Drag (long life)
12	9-6003	60347	Shield Cup - Std
13	9-6503	60339	Shield Cup - Maximum Life (requires 60347)
14	9-6004	60343	Shield Cup - Crown (requires 60347)

* CIRCLE CUTTING ATTACHMENT : See page #31

PCH/M-75 Pak Master 75, Pak Master 75XL, 625XR, Cut Master 80XL

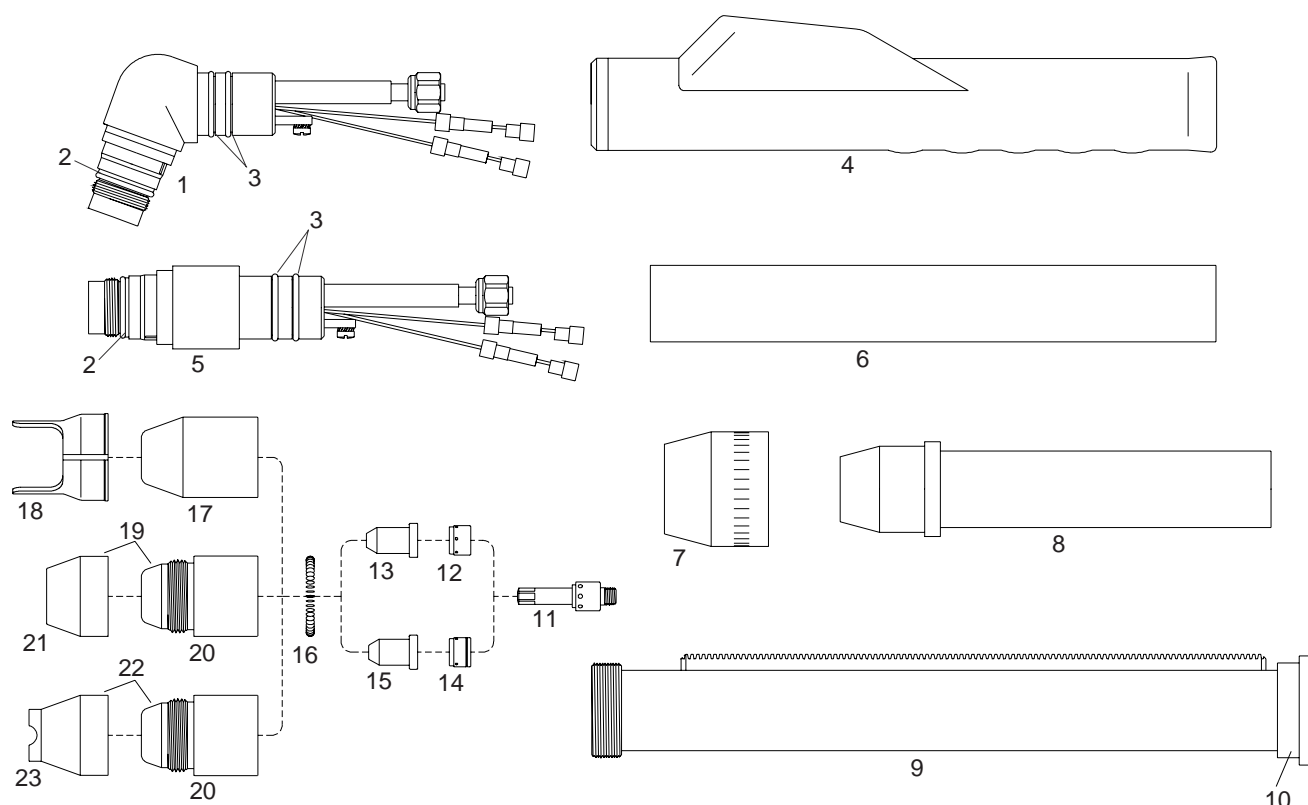

Item	Ref.	Code	Description
N/S	2-7801	07060	Hand torch complete with 25' (7.5 mts) cable
N/S	2-7802	07070	Hand torch complete with 50' (15 mts) cable
N/S	2-7805	07080	Machine torch complete with 25' (7.5 mts) cable, (with handle item 6)
N/S	2-7806	07090	Machine torch complete with 50' (15 mts) cable, (with handle item 6)
1	8-7510	07075	70° Torch Head
2	8-0532	07300.60	O-Ring (Shield Cup), (20 pcs.)
3	8-0533	07100.53	O-Ring (Handle), (20 pcs.)
4	9-5636E	07106	Handgrip complete with microswitch (incl. 9-5636, 9-7502, 8-1322)
5	8-7512	07076	180° Torch Head
6	9-5637E	07115	Machine handle
7	8-4018	TD84018	Nut
8	9-5637	TD95637	Adaptor
9	8-5005	TD85005	Positioning tube
10	8-4204	TD84204	EndCap
11	8-7502	52526/D	Electrode, long life
12	8-7501	60055	Gas distributor, cutting
13	8-7503	51296	Tip, cutting 35A - \varnothing 0,99 - .039
	8-7504	51297	Tip, cutting 55A - \varnothing 1,17 - .046
14	8-7508	60056	Gas distributor, gouging
15	8-7506	51299	Tip, Gouging - \varnothing 1,86 - .073
16	9-7501E	60442	Coil spring (10 pcs.)
17	8-7500	60440	Shield cup
18	8-7575	60444	Double pointed spacer
19	8-7496	60446	Shield cup maximum life, complete
20	8-7498	60441	Shield cup body
21	8-7497	60447	Heat shield (copper)
22	8-7507	60445	Crown shield cup assembly
23	8-7499	60443	Crown cup shield (copper)
N/S	4-7801	07063	Air and power cable 25' (7.5 mts) - Hand torch
N/S	4-7802	07073	Air and power cable 50' (15 mts) - Hand torch
N/S	4-7803	07083	Air and power cable 25' (7.5 mts) - Machine torch
N/S	4-7804	07093	Air and power cable 50' (15 mts) - Machine torch

* CIRCLE CUTTING ATTACHMENT : See page#31

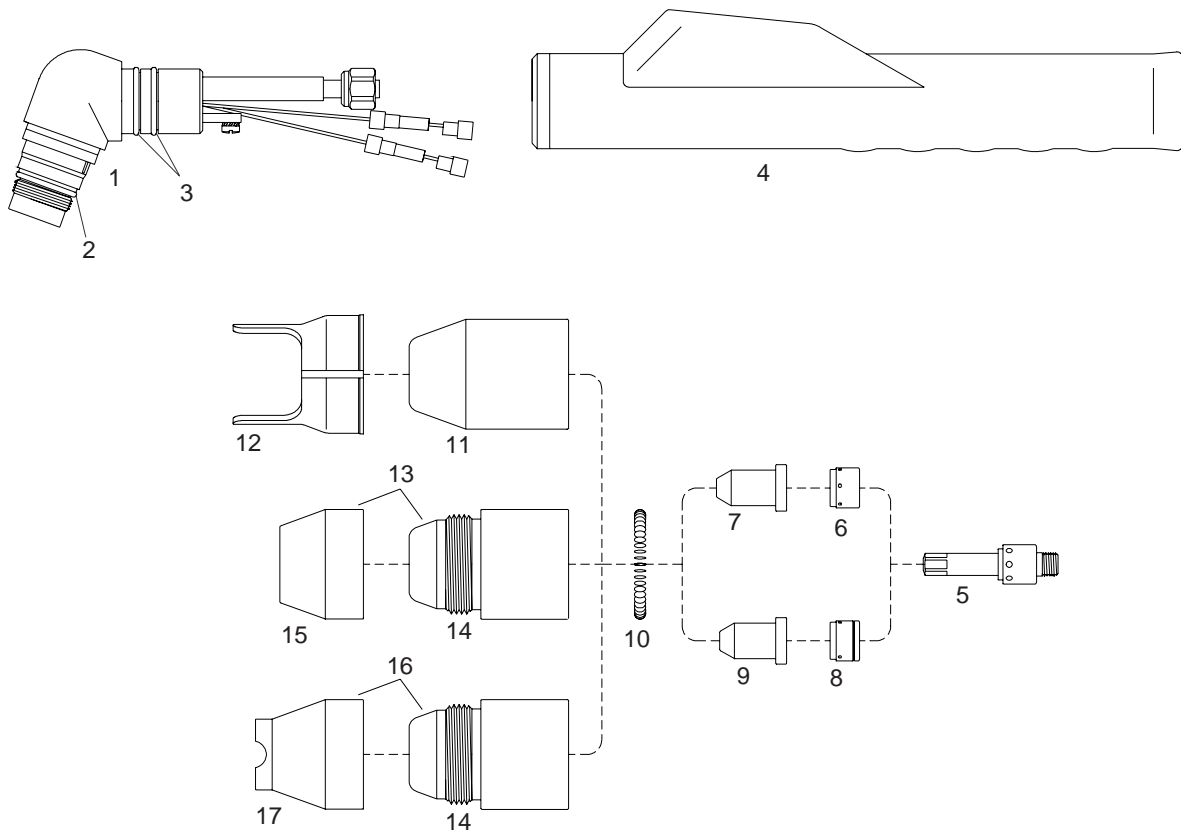
PCH/M-76 Econopak 100

Item	Ref.	Code	Description
N/S	2-7811	07060	Hand torch complete with 25' (7.5 mts) cable
N/S	2-7812	07070	Hand torch complete with 50' (15 mts) cable
1	8-7510	07075	70° Torch Head
2	8-0532	07300.60	O-Ring (Shield Cup), (20 pcs.)
3	8-0533	07100.53	O-Ring (Handle), (20 pcs.)
4	9-5636E	07106	Handgrip complete with microswitch (incl. 9-5636, 9-7502, 8-1322)
5	8-7502	52526/D	Electrode, long life
6	8-7501	60055	Gas distributor, cutting
7	8-7503	51296	Tip, cutting 35A - \varnothing 0,99 - .039
	8-7505	51298	Tip, cutting 60A - \varnothing 1,32 - .052
8	8-7508	60056	Gas distributor, gouging
9	8-7506	51299	Tip, Gouging - \varnothing 1,86 - .073
10	9-7501E	60442	Coil spring (10 pcs.)
11	8-7500	60440	Shield cup
12	8-7575	60444	Double pointed spacer
13	8-7496	60446	Shield cup maximum life, complete
14	8-7498	60441	Shield cup body
15	8-7497	60447	Heat shield (copper)
16	8-7507	60445	Crown shield cup assembly
17	8-7499	60443	Crown cup shield (copper)
N/S	4-7611	07063	Air and power cable 25' (7.5 mts) - Hand torch
N/S	4-7612	07073	Air and power cable 50' (15 mts) - Hand torch

* CIRCLE CUTTING ATTACHMENT : See page #31

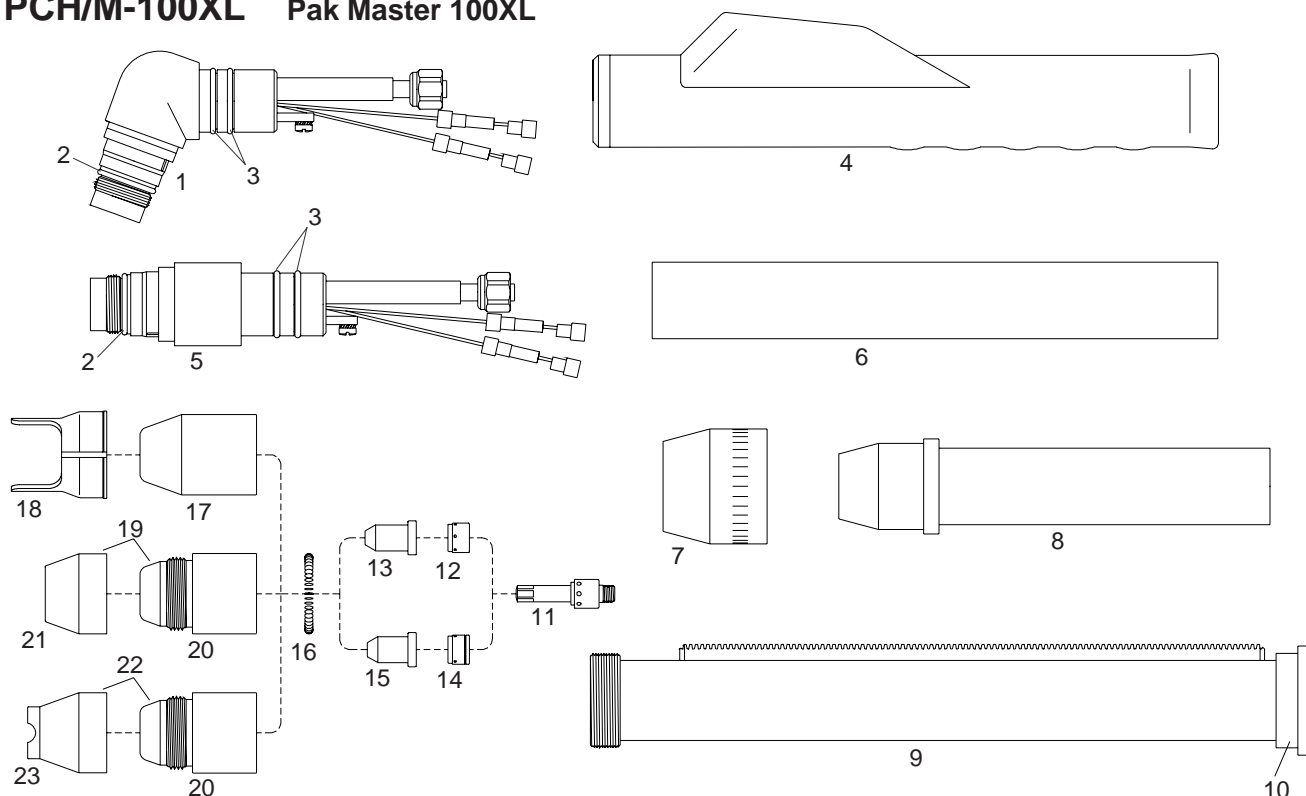
PCH/M-100XL Pak Master 100XL

Item	Ref.	Code	Description
N/S	2-0801	07060	Hand torch complete with 25' (7.5 mts) cable
N/S	2-0802	07070	Hand torch complete with 50' (15 mts) cable
N/S	2-0805	07080	Machine torch complete with 25' (7.5 mts) cable, (with handle item 6)
N/S	2-0806	07090	Machine torch complete with 50' (15 mts) cable, (with handle item 6)
1	8-7510	07075	70° Torch Head
2	8-0532	07300.60	O-Ring (Shield Cup), (20 pcs.)
3	8-0533	07100.53	O-Ring (Handle), (20 pcs.)
4	9-5636E	07106	Handgrip complete with microswitch (incl. 9-5636, 9-7502, 8-1322)
5	8-7512	07076	180° Torch Head
6	9-5637E	07115	Machine handle
7	8-4018	TD84018	Nut
8	9-5637	TD95637	Adaptor
9	8-5005	TD85005	Positioning tube
10	8-4204	TD84204	EndCap
11	8-7502	52526/D	Electrode, long life
12	8-7501	60055	Gas distributor, cutting
13	8-7503	51296	Tip, cutting 35A - \varnothing 0,99 - .039
	8-7504	51297	Tip, cutting 55A - \varnothing 1,17 - .046
	8-7505	51298	Tip, cutting 70A - \varnothing 1,32 - .052
14	8-7508	60056	Gas distributor, gouging
15	8-7506	51299	Tip, Gouging - \varnothing 1,86 - .073
16	9-7501E	60442	Coil spring (10 pcs.)
17	8-7500	60440	Shield cup
18	8-7575	60444	Double pointed spacer
19	8-7496	60446	Shield cup maximum life, complete
20	8-7498	60441	Shield cup body
21	8-7497	60447	Heat shield (copper)
22	8-7507	60445	Crown shield cup assembly
23	8-7499	60443	Crown cup shield (copper)
N/S	4-0810	07063	Air and power cable 25' (7.5 mts) - Hand torch
N/S	4-0811	07073	Air and power cable 50' (15 mts) - Hand torch
N/S	4-0812	07083	Air and power cable 25' (7.5 mts) - Machine torch
N/S	4-0813	07093	Air and power cable 50' (15 mts) - Machine torch

* CIRCLE CUTTING ATTACHMENT : See page#31

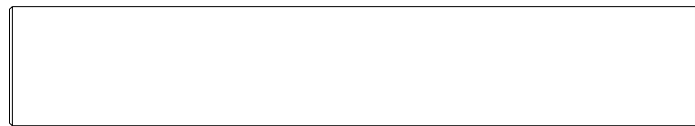
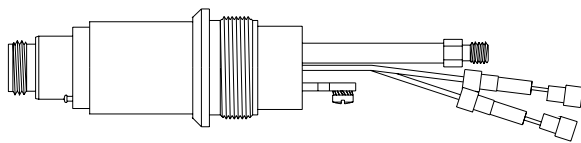
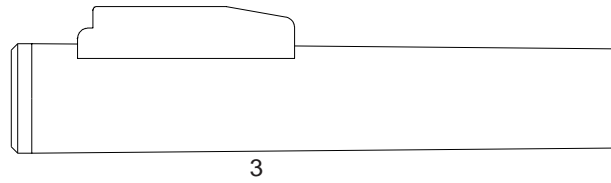
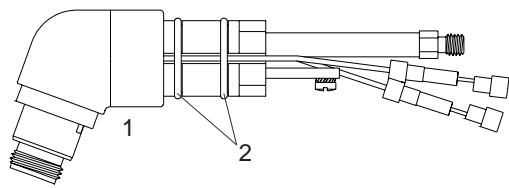
PCH/M-40 Pak Master 50XL Plus

4

5

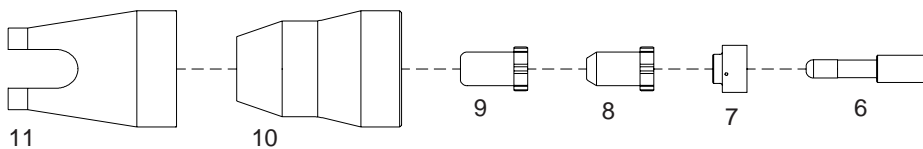

11

10

9

8

7

6

Item	Ref.	Code	Description
N/S	2-5035	07022	Hand torch complete with 25' (7.5 mts) cable
N/S	2-5036	07032	Hand torch complete with 50' (15 mts) cable
N/S	2-5039	07042	Machine torch complete with 25' (7.5 mts) cable
N/S	2-5040	07052	Machine torch complete with 50' (15 mts) cable
1	9-8055	07037	70° Torch head
2	8-0533	07100.53	O-Ring (20 pcs.)
3	9-8059	07103	Handgrip complete with microswitch
4	9-8053	07038	180° Torch head
5	9-7833	07215	Machine handle
6	9-6506	52523/D	Electrode - Hf (long life)
7	9-6507	60051	Gas Distributor (long life)
8	9-6501	51289	Tip - Drag (long life)
9	9-6500	51288	Tip - Standoff (long life)
	9-6502	51288.12	Tip - Gouging
10	9-6003	60347	Shield Cup - Std
11	9-6004	60343	Shield Cup - Crown (requires 9-6003)
N/S	4-0815	07023	Air and power cable 25' (7.5 mts) - Hand torch
N/S	4-0816	07033	Air and power cable 50' (15 mts) - Hand torch
N/S	4-2897	07043	Air and power cable 25' (7.5 mts) - Machine torch
N/S	4-2898	07053	Air and power cable 50' (15 mts) - Machine torch

* CIRCLE CUTTING ATTACHMENT : Seepage#31

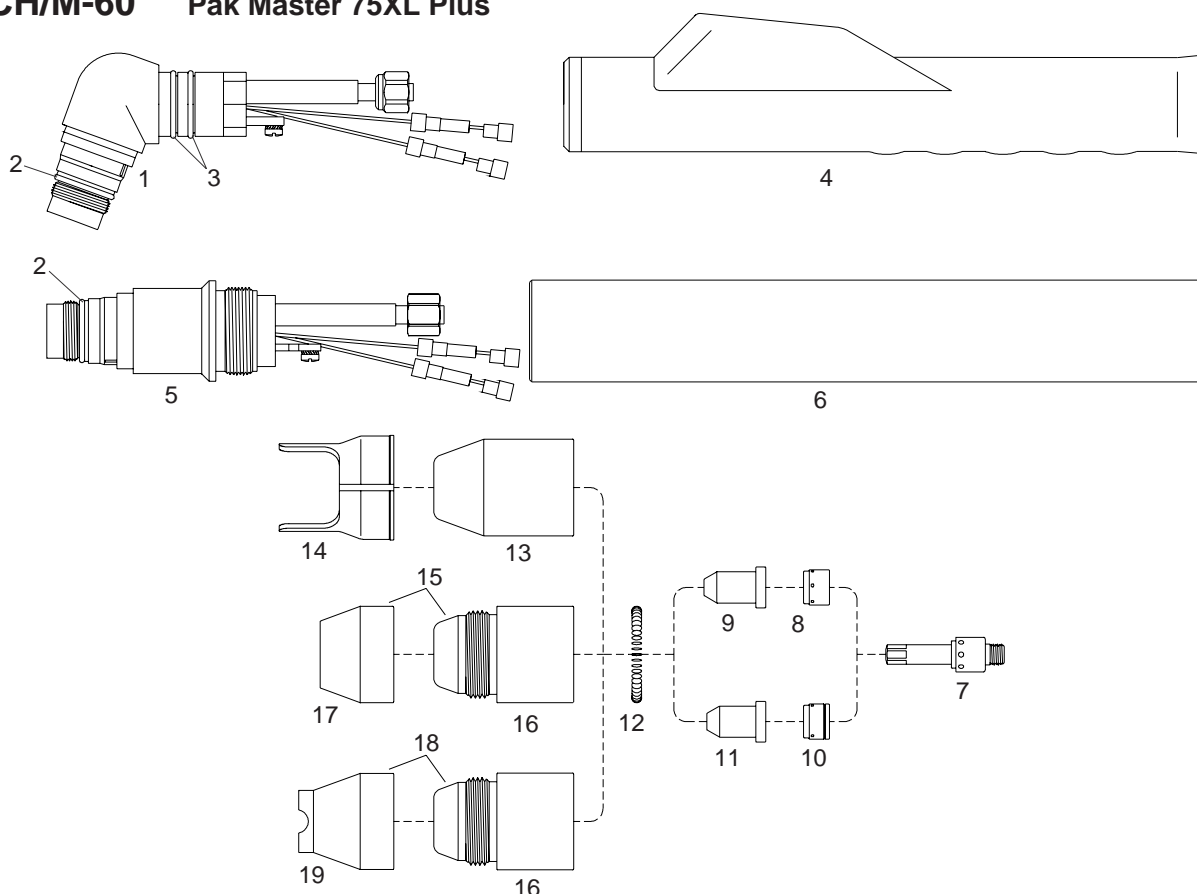
PCH/M-60 Pak Master 75XL Plus

Item	Ref.	Code	Description
N/S	2-6660	07061	Hand torch complete with 25' (7.5 mts) cable
N/S	2-6661	07071	Hand torch complete with 50' (15 mts) cable
N/S	2-6664	07081	Machine torch complete with 25' (7.5 mts) cable
N/S	2-6665	07091	Machine torch complete with 50' (15 mts) cable
1	9-8075	07077	70° Torch Head
2	8-0533	07100.53	O-Ring (Handle), (20 pcs.)
3	8-0532	07300.60	O-Ring (Shield Cup), (20 pcs.)
4	9-8066	07106	Handgrip complete with microswitch
5	9-8073	07078	180° Torch Head
6	9-7833	07215	Machine handle
7	8-7502	52526/D	Electrode, long life
8	8-7501	60055	Gas distributor, cutting
9	8-7503	51296	Tip, cutting 35A - \varnothing 0,99 - .039
	9-7726	51297.13	Tip, cutting 60A - \varnothing 1,24 - .049
10	8-7508	60056	Gas distributor, gouging
11	8-7506	51299	Tip, Gouging - \varnothing 1,86 - .073
12	9-7501E	60442	Coil spring (10 pcs.)
13	8-7500	60440	Shield cup
14	8-7575	60444	Double pointed spacer
15	8-7496	60446	Shield cup maximum life, complete
16	8-7498	60441	Shield cup body
17	8-7497	60447	Heat shield (copper)
18	8-7507	60445	Crown shield cup assembly
19	8-7499	60443	Crown cup shield (copper)
N/S	4-0819	07063	Air and power cable 25' (7.5 mts) - Hand torch
N/S	4-0820	07073	Air and power cable 50' (15 mts) - Hand torch
N/S	4-7502	07083	Air and power cable 25' (7.5 mts) - Machine torch
N/S	4-7503	07093	Air and power cable 50' (15 mts) - Machine torch

* CIRCLE CUTTING ATTACHMENT : See page#31

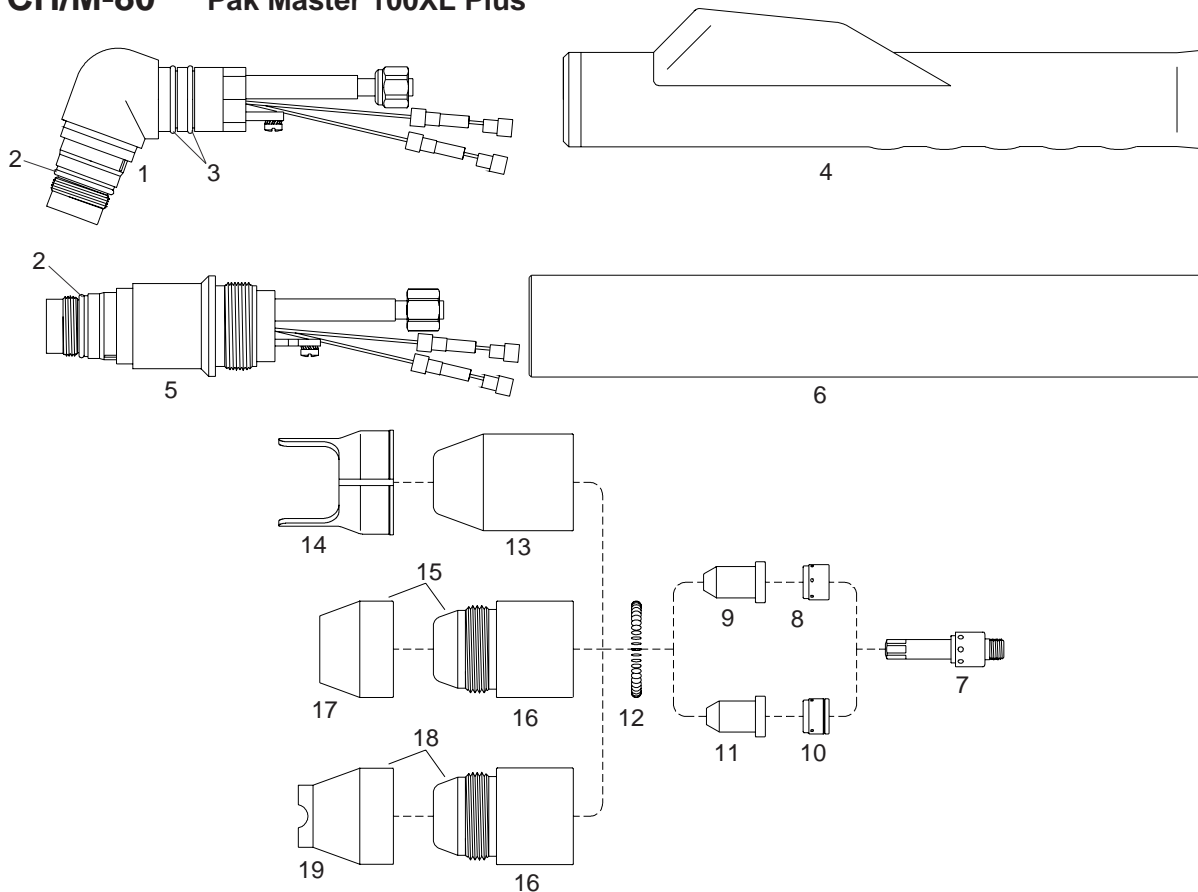
PCH/M-80 Pak Master 100XL Plus

Item	Ref.	Code	Description
N/S	2-0080	07062	Hand torch complete with 25' (7.5 mts) cable
N/S	2-0081	07072	Hand torch complete with 50' (15 mts) cable
N/S	2-0084	07082	Machine torch complete with 25' (7.5 mts) cable
N/S	2-0085	07092	Machine torch complete with 50' (15 mts) cable
1	9-8075	07077	70° Torch Head
2	8-0532	07300.60	O-Ring (Shield Cup), (20 pcs.)
3	8-0533	07100.53	O-Ring (Handle), (20 pcs.)
4	9-8066	07106	Handgrip complete with microswitch
5	9-8073	07078	180° Torch Head
6	9-7833	07215	Machine handle
7	8-7502	52526/D	Electrode, long life
8	8-7501	60055	Gas distributor, cutting
9	8-7503	51296	Tip, cutting 35A - \varnothing 0,99 - .039
	8-7504	51297	Tip, cutting 55A - \varnothing 1,17 - .046
	9-7728	51298.14	Tip, cutting 80A - \varnothing 1,39 - .055
10	8-7508	60056	Gas distributor, gouging
11	8-7506	51299	Tip, Gouging - \varnothing 1,86 - .073
12	9-7501E	60442	Coil spring (10 pcs.)
13	8-7500	60440	Shield cup
14	8-7575	60444	Double pointed spacer
15	8-7496	60446	Shield cup maximum life, complete
16	8-7498	60441	Shield cup body
17	8-7497	60447	Heat shield (copper)
18	8-7507	60445	Crown shield cup assembly
19	8-7499	60443	Crown cup shield (copper)
N/S	4-0823	07064	Air and power cable 25' (7.5 mts) - Hand torch
N/S	4-0824	07074	Air and power cable 50' (15 mts) - Hand torch
N/S	4-0012	07084	Air and power cable 25' (7.5 mts) - Machine torch
N/S	4-0013	07094	Air and power cable 50' (15 mts) - Machine torch

* CIRCLE CUTTING ATTACHMENT : Seepage#31

PCH/M-120 Pak Master 150XL

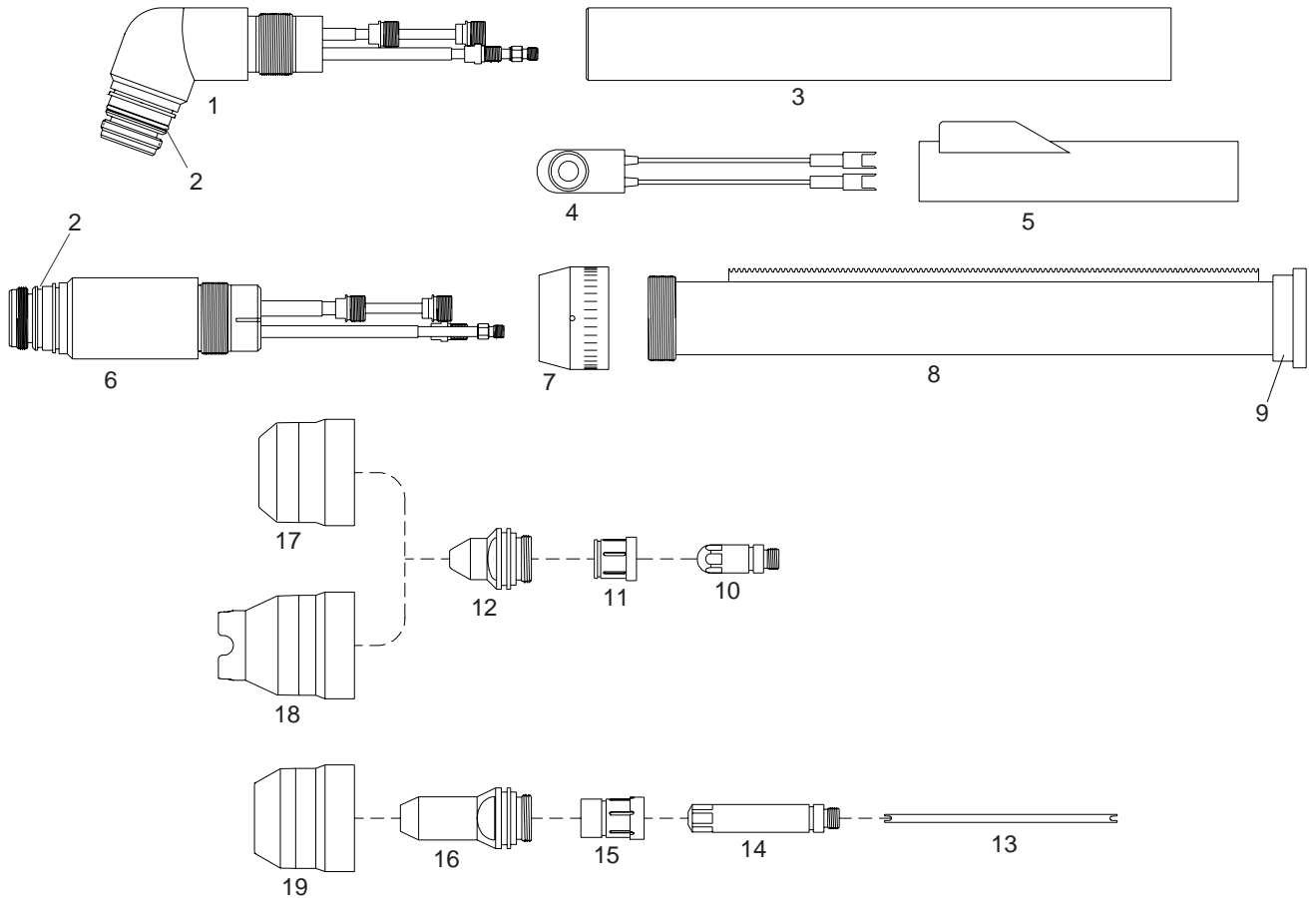

Item	Ref.	Code	Description
1	9-7830	TD97830	70° Torch Head
N/S	9-7831	TD97831	90° Torch Head
2	8-0538	TD80538	O-Ring (10 pcs.)
3	9-7833	07215	Handle
4	9-1246	TD91246	Switch
5	8-4216	TD84216	Switch Sheath
6	9-6410	TD96410	180° Torch Head
7	8-2158	TD82158	Adaptor
8	7-3207	TD73207	Positioning tube
9	8-4204	TD84204	Endcap
10	20-1210	52612	Electrode Air - Cutting
	20-1211	TD201211	Electrode Multi Gas - Cutting
11	20-1215	TD201215	Gas Distributor - Cutting
12	20-1220	51360	Tip 35A
	20-1221	51361	Tip 70A
	20-1222	51362	Tip 120A
13	20-1402	TD201402	Coolant Tube extension - Gouging
14	20-1404	TD201404	Electrode Air/N2 - Gouging
	20-1405	TD201405	Electrode Ar/H2 - Gouging
15	20-1409	TD201409	Gas Distributor - Gouging
16	20-1412	TD201412	Tip .110 - Gouging
	20-1413	TD201413	Tip .125 - Gouging
	20-1414	TD201414	Tip .156 - Gouging
	20-1415	TD201415	Tip .171 - Gouging
17	20-1225	TD201225	Shield Cup - Std.
18	20-1226	TD201226	Shield Cup - Crown
19	20-1227	TD201227	Shield Cup - Gouging

* CIRCLE CUTTING ATTACHMENT : See page#31

PCH/M-70 Stak Pak

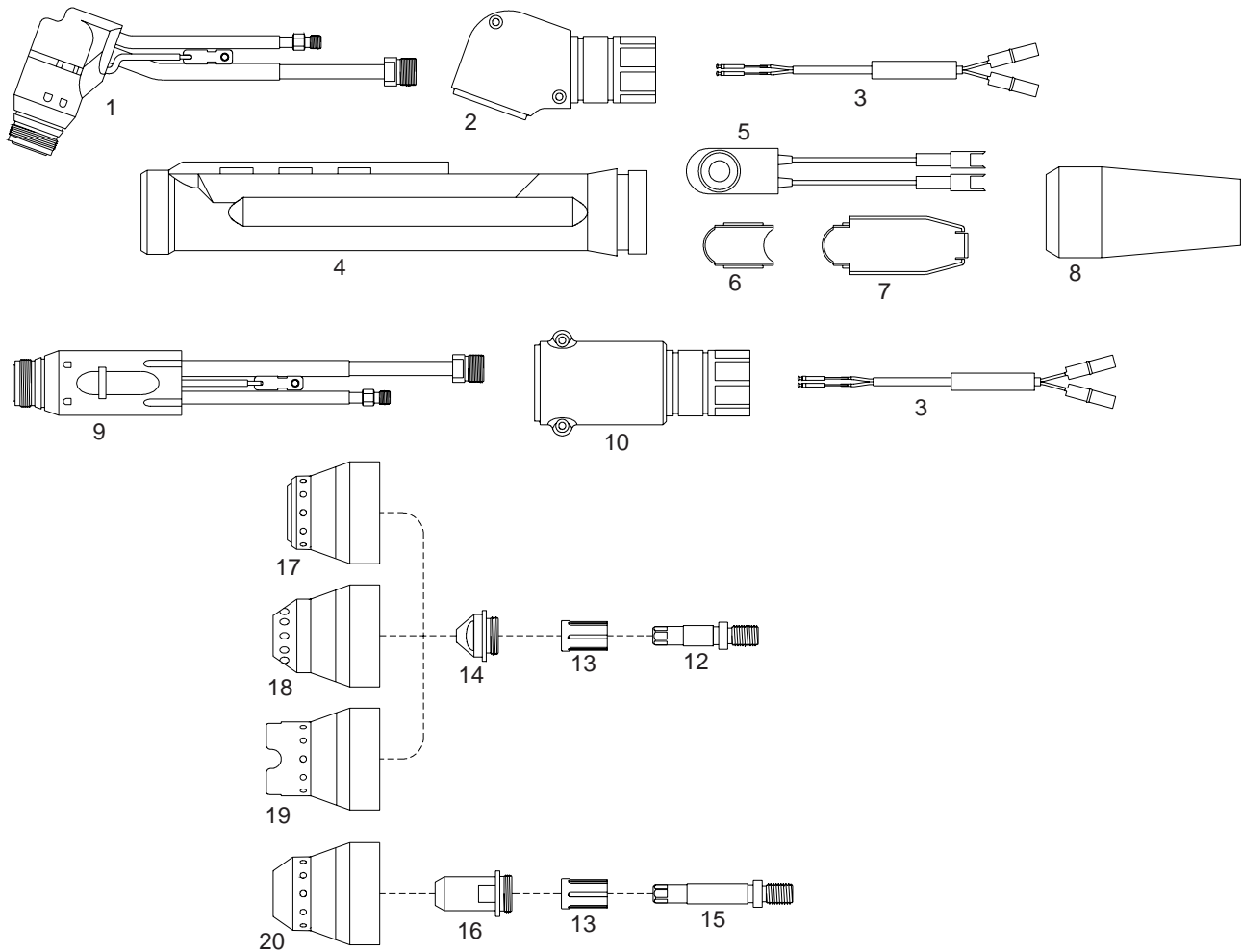

Item	Ref.	Code	Description
1	9-5810	TD95810	70° Torch Head
N/S	9-5859	TD95859	70° Torch Shell Complete
2	9-6266	TD96266	70° Torch Shell
N/S	9-5811	TD95811	90° Torch Head
N/S	9-5860	TD95860	90° Torch Shell Complete
N/S	9-6264	TD96264	90° Torch Shell
3	9-6162	TD96162	Pipewire assembly
4	8-4309	TD84309	Torch Handle
5	9-1246	TD91246	Switch
6	8-4302	TD84302	Insert
7	8-4303	TD84303	Closure
8	8-4308	TD84308	Boot
9	9-5812	TD95812	180° Torch Head
N/S	9-5861	TD95861	180° Torch Shell Complete
10	9-6265	TD96265	180° Torch Shell
12	9-6019	52524/A	Electrode - Cutting, Air/N2/O2
	9-6021	TD96021	Electrode - Cutting, Ar/H2
13	9-6022	TD96022	Gas Distributor
14	9-6008	51294	Tip - Cutting 35A Air/N2/O2
	9-6009	51295	Tip - Cutting 70A Air/N2/O2
	9-6013	TD96013	Tip - Cutting 70A Ar/H2
15	9-6107	TD96107	Electrode - Gouging, Air/N2/O2
	9-6108	TD96108	Electrode - Gouging, Ar/H2
16	9-6014	TD96014	Tip - Gouging .089
	9-6015	TD96015	Tip - Gouging .104
	9-6109	TD96109	Tip - Gouging .125
17	9-6016	60345	Shield Cup - Standoff - Std.
18	9-6024	TD96024	Shield Cup - Standoff - Long
19	9-6017	60346	Shield Cup - Crown
20	9-6018	60344	Shield Cup - Gouging

PCH/M-140 Stak Pak

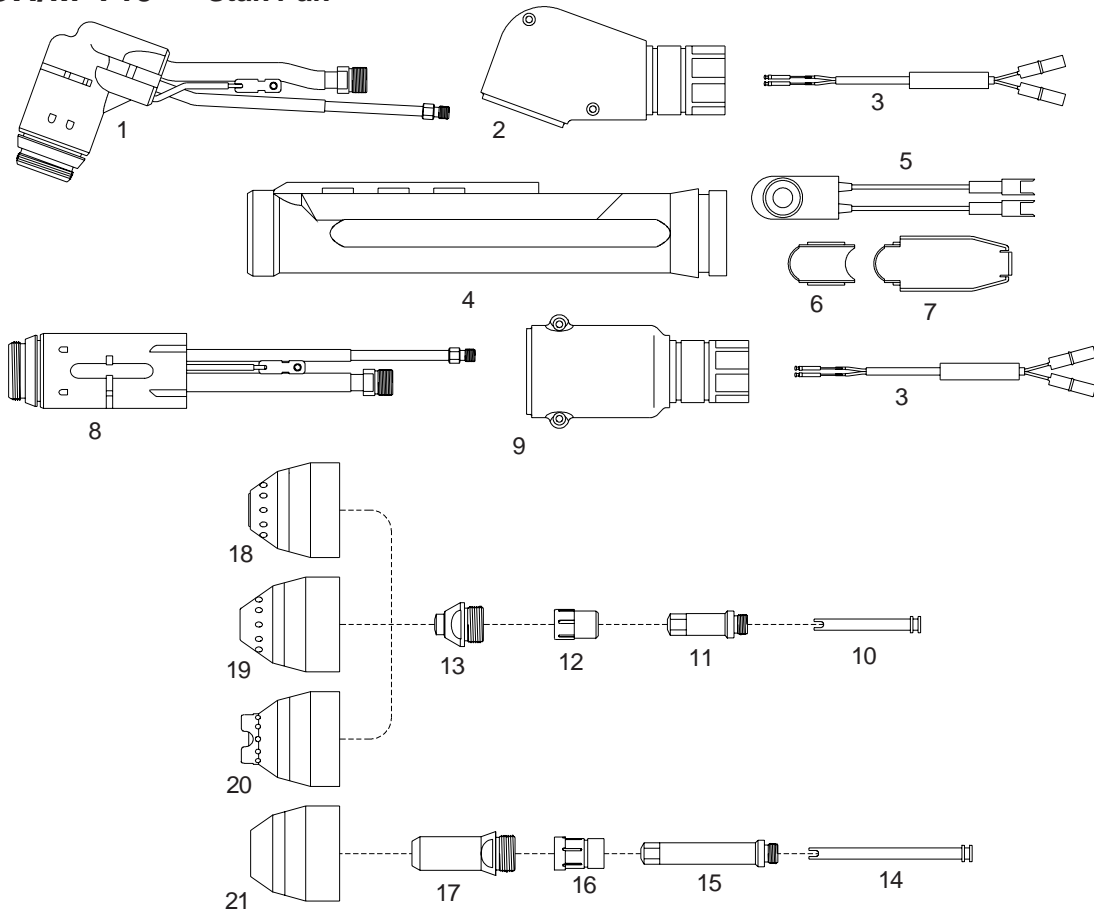

Item	Ref.	Code	Description
1	9-5813	TD95813	70° Torch Head
2	9-5826	TD95826	70° Torch Shell
N/S	9-5814	TD95814	90° Torch Head
N/S	9-5827	TD95827	90° Torch Shell
3	9-4532	TD94532	Pip Wire Assembly
4	8-4312	TD84312	Torch Handle
5	9-1246	TD91246	Switch
6	8-4302	TD84302	Insert
7	8-4303	TD84303	Closure
8	9-5815	TD95815	180° Torch Head
9	9-5828	TD95828	180° Torch Shell
10	9-6052	TD96052	Cooling Tube - Cutting
11	9-6048	52608	Electrode - Cutting, Air/N2/O2
	9-6050	TD96050	Electrode - Cutting, Ar/H2
12	9-6051	TD96051	Gas Distributor - Cutting
13	9-6025	51585	Tip - Cutting 35A Air/N2
	9-6026	51586	Tip - Cutting 70A Air/N2
	9-6027	51587	Tip - Cutting 105A Air/N2
	9-6028	51588	Tip - Cutting 140A Air/N2
	9-6034	TD96034	Tip - Cutting 70A Ar/H2
	9-6035	TD96035	Tip - Cutting 105A Ar/H2
	9-6036	TD96036	Tip - Cutting 140A Ar/H2
14	9-6113	TD96113	Cooling Tube - Gouging
15	9-6110	TD96110	Electrode - Gouging, Air/N2/O2
	9-6111	TD96111	Electrode - Gouging, Ar/H2
16	9-6112	TD96112	Gas Distributor - Gouging
17	9-6037	TD96037	Tip - Gouging .110
	9-6038	TD96038	Tip - Gouging .125
	9-6039	TD96039	Tip - Gouging .156
	9-6040	TD96040	Tip - Gouging .171
18	9-6045	TD96045	Shield Cup - Standoff - Std.
19	9-6054	TD96054	Shield Cup - Standoff - Long
20	9-6046	TD96046	Shield Cup - Crown
21	9-6047	TD96047	Shield Cup - Gouging

PCH-145 Stak Pak

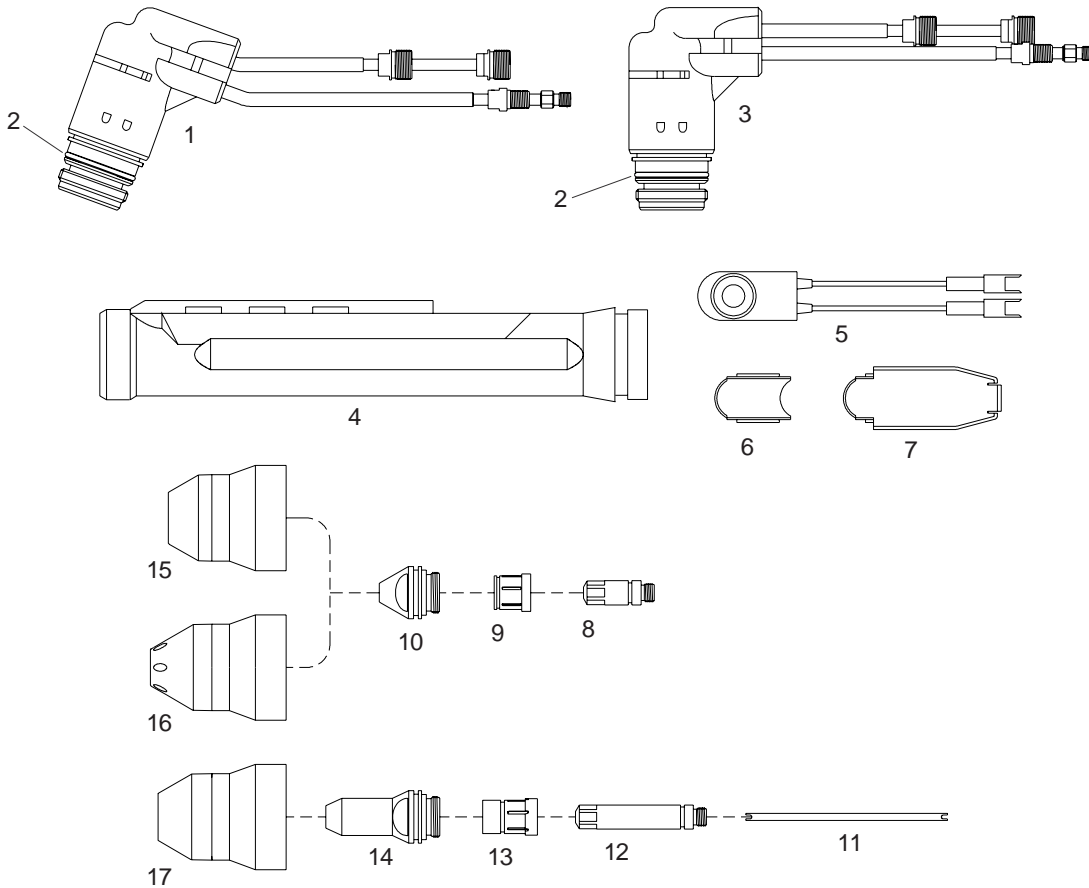

Item	Ref.	Code	Description
1	9-5816	TD95816	70° Torch Head
2	8-0538	TD80538	O-Ring (10 pcs.)
3	9-5817	TD95817	90° Torch Head
4	8-4312	TD84312	Torch Handle
5	9-1246	TD91246	Switch
6	8-4302	TD84302	Insert
7	8-4303	TD84303	Closure
8	9-6078	TD96078	Electrode - Cutting, Air
	9-6129	TD96129	Electrode - Cutting, N2
	9-6080	TD96080	Electrode - Cutting, Ar/H2
9	9-6081	TD96081	Gas Distributor - Cutting
10	9-6055	TD96055	Tip - Cutting 35A Air/N2
	9-6056	51370.13	Tip - Cutting 70A Air/N2
	9-6057	51370.15	Tip - Cutting 105A Air/N2
	9-6058	51370.17	Tip - Cutting 140A Air/N2
	9-6064	TD96064	Tip - Cutting 70A Ar/H2
	9-6065	TD96065	Tip - Cutting 105A Ar/H2
	9-6066	TD96066	Tip - Cutting 140A Ar/H2
11	20-1403	TD201403	Coolant Tube extension - Gouging
12	20-1404	TD201404	Electrode - Gouging, Air/N2/O2 (replaces TD96130)
	20-1405	TD201405	Electrode - Gouging, Ar/H2 (replaces TD96131)
13	20-1409	TD201409	Gas Distributor - Gouging (replaces TD96082)
14	20-1415	TD201415	Tip - Gouging .171 (replaces TD96067)
	20-1416	TD201416	Tip - Gouging .209 (replaces TD96068)
	20-1417	TD201417	Tip - Gouging .246 (replaces TD96069)
	20-1418	TD201418	Tip - Gouging .246 (replaces TD96070)
15	9-6075	TD96075	Shield Cup - Standoff - Std.
16	9-6083	TD96083	Shield Cup - Standoff - Long
17	20-1424	TD201424	Shield Cup - Gouging - Hand (replaces TD96077)

PCM-145 Stak Pak, TD750, Merlin 3000, Pak 15XC w/Max 300 retrofit

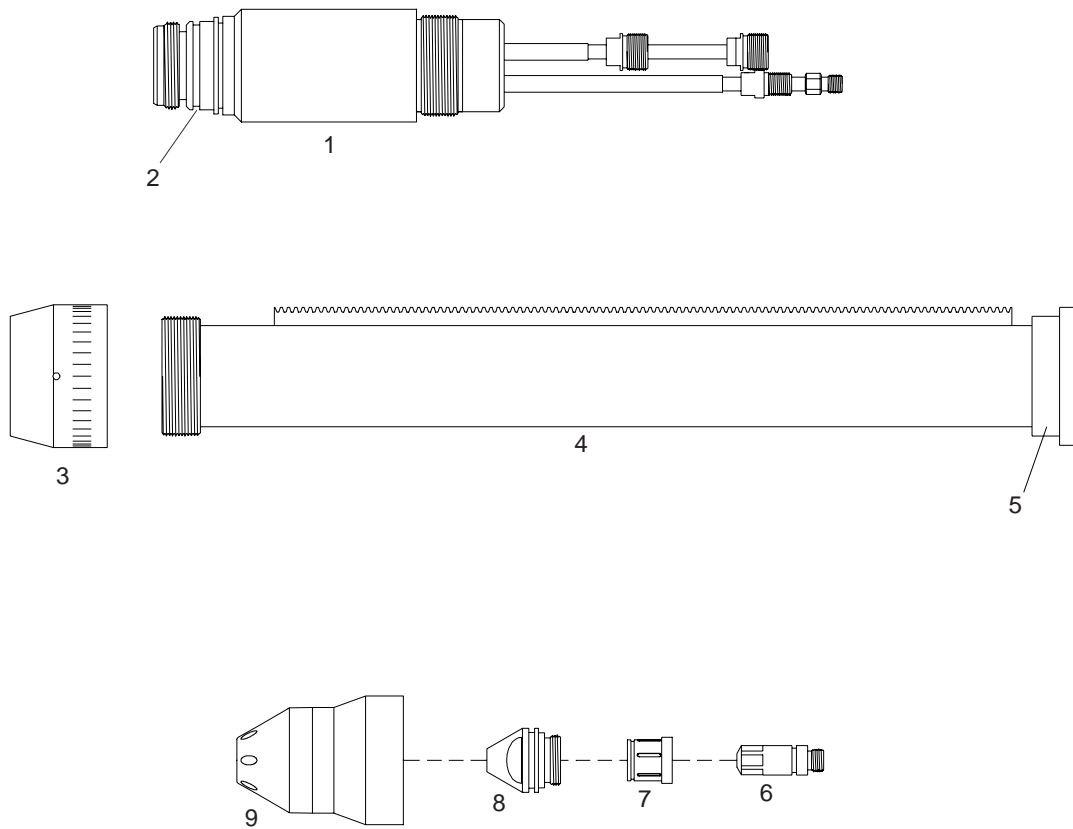

Item	Ref.	Code	Description
1	9-6410	TD96410	180° Torch Head
2	8-0538	TD80538	O-Ring (10 pcs.)
3	8-2158	TD82158	Adaptor
4	7-3207	TD73207	Positioning Tube
5	8-4204	TD84204	EndCap
6	20-1018	TD201018	Electrode Air/O2
	20-1023	TD201023	Electrode N2 (replaces TD96431)
	20-1025	TD201025	Electrode Ar/H2 (replaces TD96427)
7	9-6416	TD96416	Gas Distributor
8	9-6424	51370.13	Tip Cutting 70A Air/N2
	9-6425	51370.15	Tip Cutting 105A Air/N2
	9-6426	51370.17	Tip Cutting 140A Air/N2
	9-6419	TD96419	Tip Cutting 70A O2
	9-6420	TD96420	Tip Cutting 105A O2
	9-6421	TD96421	Tip Cutting 140A O2
	9-6428	TD96428	Tip Cutting 70A Ar/H2
	9-6429	TD96429	Tip Cutting 105A Ar/H2
	9-6430	TD96430	Tip Cutting 140A Ar/H2
9	9-6411	TD96411	Shield Cup - Standoff - Long O2
	9-6412	TD96412	Shield Cup - Standoff - Long Air/N2 Ar/H2

PCH/M-150 Pak 15XC

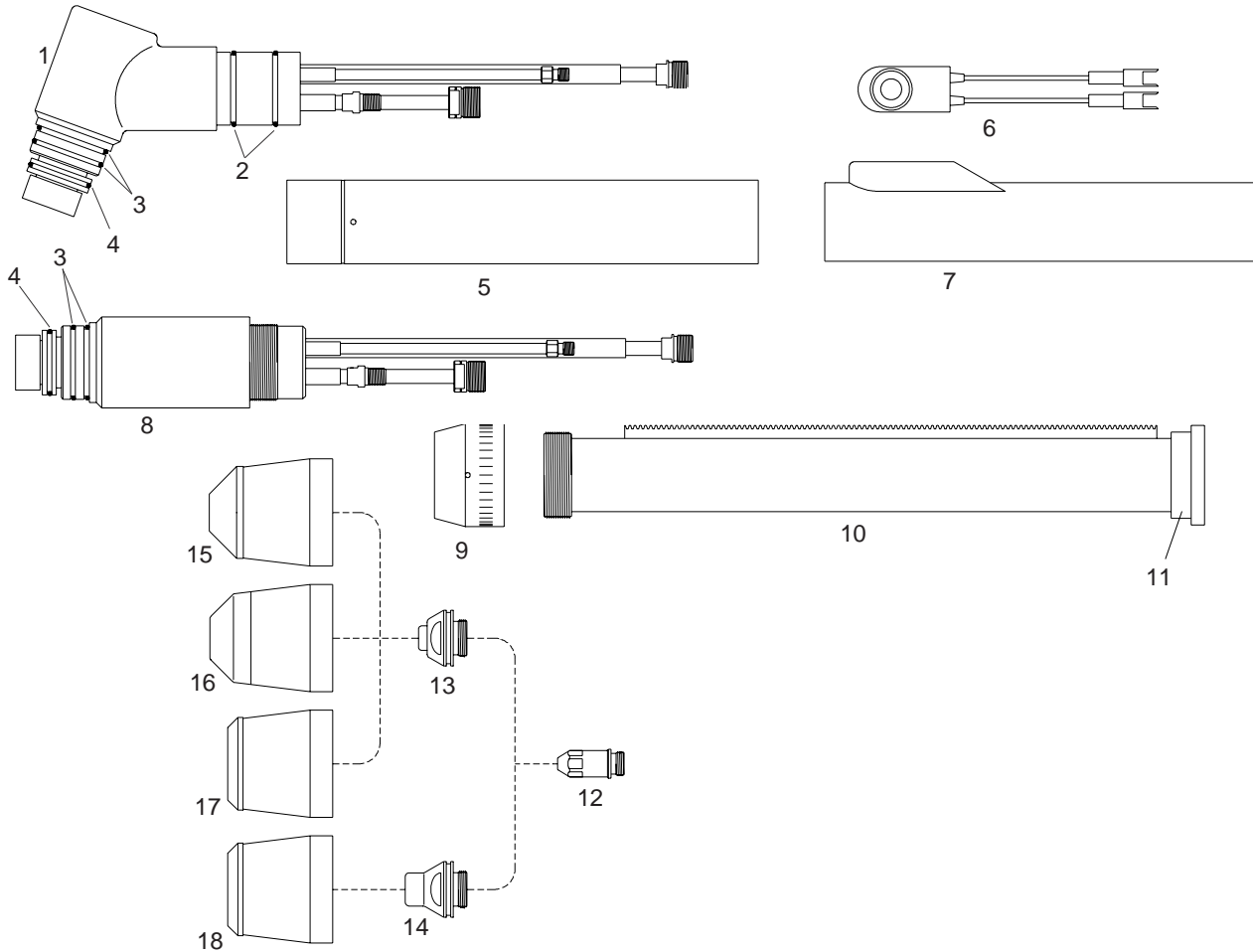

Item	Ref.	Code	Description
1	9-5743	TD95743	70° Torch Head
N/S	9-5744	TD95744	90° Torch Head
2	8-5570	TD85570	O-Ring (Handle), (10 pcs.)
3	8-0540	TD80540	O-Ring (Shield Cup, Lg.), (10 pcs.)
4	8-0537	TD80537	O-Ring (Shield Cup, Sm.), (10 pcs.)
5	9-1063	TD91063	Handle
6	9-1246	TD91246	Switch
7	9-1064	TD91064	Switch Sheath
8	9-5745	TD95745	180° Torch Head
9	8-2158	TD82158	Adaptor
10	7-3207	TD73207	Positioning Tube
11	8-4204	TD84204	End Cap
12	9-5749	52610	Electrode - Air
	9-5760	52611	Electrode - O2
	9-5754	TD95754	Electrode - N2, Ar - H2
13	9-5748	51580	Tip ø 1,09 - .043 - 50A Air
	9-5747	51581	Tip ø 1,40 - .055 - 100A Air
	9-5746	51582	Tip ø 1,78 - .070 - 150A Air
	9-5753	51365	Tip 50A O2
	9-5752	51366	Tip 100A O2
	9-5751	51367	Tip 150A O2
	9-5765	TD95765	Tip 50A N2
	9-5766	TD95766	Tip 100A N2
	9-5767	TD95767	Tip 150A N2
	9-5775	TD95775	Tip 150A Ar/H2
14	9-5756	TD95756	Tip - Gouging 85A .078
	9-5755	TD95755	Tip - Gouging 150A .120
15	9-5750	60390	Shield Cup - Ceramic Front
16	9-5790	60393	Shield Cup - Std. - Metal Front
17	9-5801	TD95801	Shield Cup - Copper (Tip Exp.)
	9-5758	60391	Shield Cup - Ceramic (Tip Exp.)
18	9-5774	60392	Shield Cup - Gouging

Maximizer 300 Merlin 1000

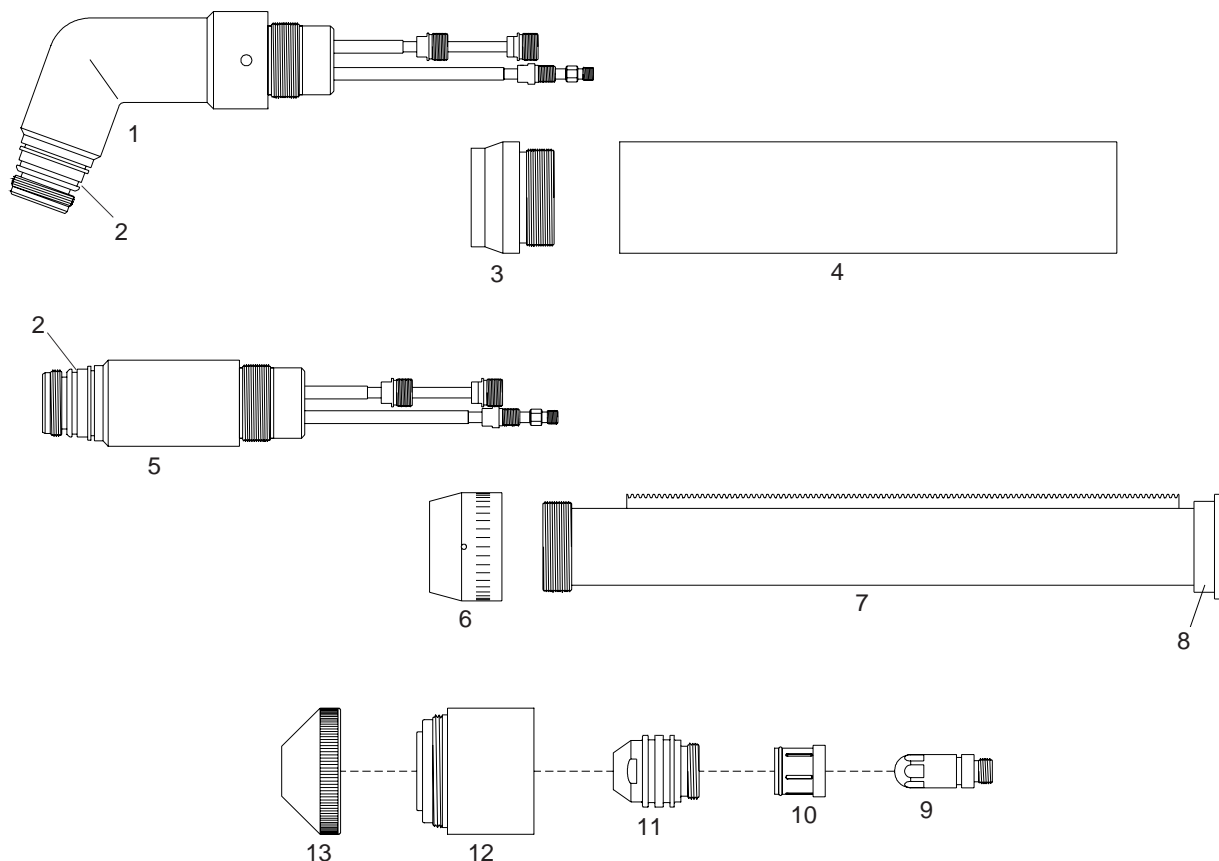

Item	Ref.	Code	Description
1	9-6457	TD96457	70° Torch Head
N/S	9-6459	TD96459	90° Torch Head
2	8-0538	TD80538	O-Ring (10 pcs.)
3	9-6767	TD96767	Adaptor
4	9-6769	TD96769	Mounting Tube
5	9-6410	TD96410	180° Torch Head
6	8-2158	TD82158	Adaptor
7	7-3207	TD73207	Positioning Tube
8	8-4204	TD84204	EndCap
9	20-1016	TD201016	Electrode O2
	20-1018	TD201018	Electrode Air
	20-1023	TD201023	Electrode N2
	20-1025	TD201025	Electrode Ar/H2
10	20-0008	TD200008	Gas Distributor 50-225A
11	20-1030	51350	Tip 50A O2/N2/Air
	20-1031	51351	Tip 100A O2/N2/Air
	20-1034	51354	Tip 300A
12	20-1002	60396	Shield Cup Body
	20-1029	60397	Shield Cup Body, Underwater
13	20-1003	51990	End Cup 50A
	20-1004	51991	End Cup 100A
	20-1028	TD201028	End Cup, Underwater
SQUARE CUT, 50A, O₂-O₂ CONSUMABLES			
9	20-1050	TD201050	Electrode Cutting O2
10	20-0008	TD200008	Gas Distributor, Cutting
11	20-1051	TD201051	Tip Cutting 50A
12	20-1002	60396	Shield Cup Body
13	20-1052	TD201052	Shield Cup End Cup, 50A

Maximizer 300 Merlin 3000, Merlin 6000

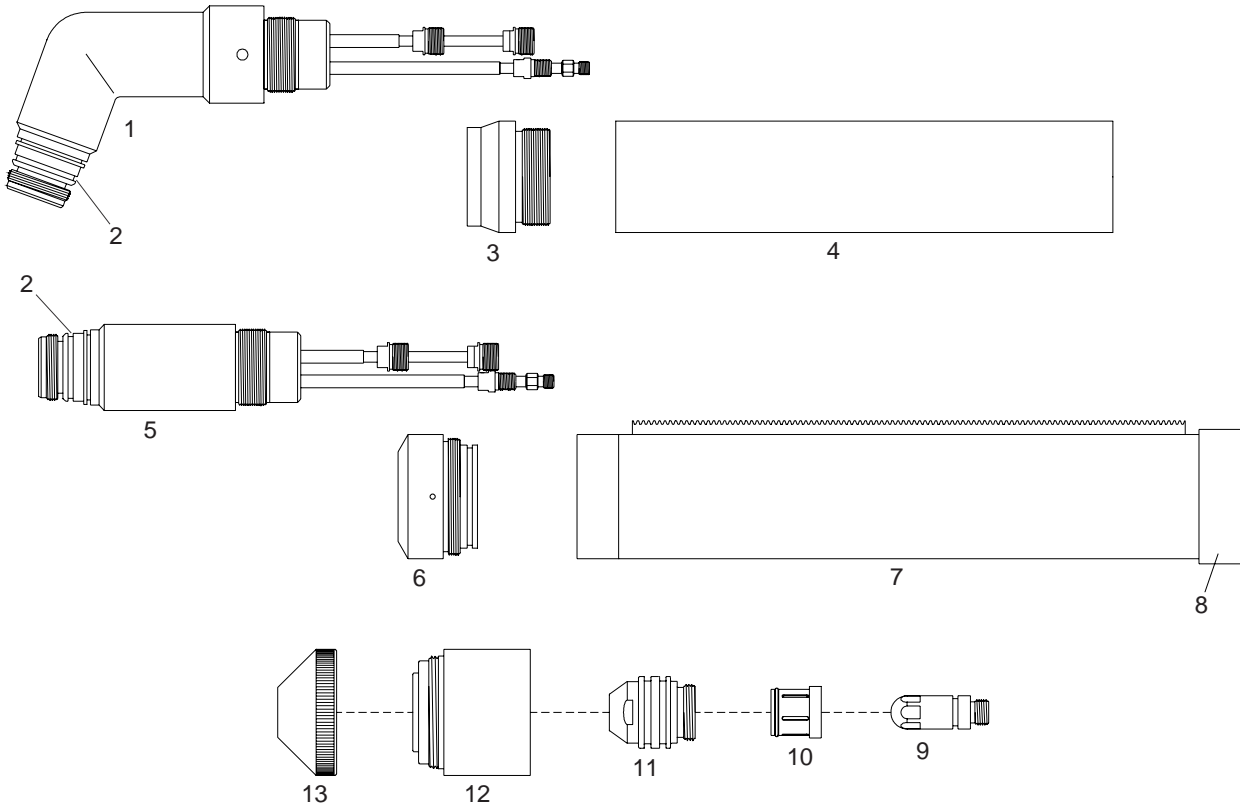

Item	Ref.	Code	Description
1	9-6457	TD96457	70° Torch Head
N/S	9-6459	TD96459	90° Torch Head
2	8-0538	TD80538	O-Ring (10 pcs.)
3	9-6767	TD96767	Adaptor
4	9-6769	TD96769	Mounting Tube
5	9-6410	TD96410	180° Torch Head
6	8-3322	TD83322	Adaptor
7	9-6819	TD96819	Positioning Tube
8	8-6522	TD86522	EndCap
9	20-1010	TD201010	Electrode O2 100-225A
	20-1015	TD201015	Electrode O2 100A
	20-1016	TD201016	Electrode O2 150A
	20-1017	TD201017	Electrode O2 225A
	20-1018	TD201018	Electrode Air 50-225A
	20-1021	TD201021	Electrode Air/O2 300A
	20-1023	TD201023	Electrode N2 50-300A
	20-1025	TD201025	Electrode Ar/H2 100-300A
	20-1050	TD201050	Electrode - Cutting O2
10	20-0008	TD200008	Gas Distributor 50-225A
	20-1009	TD201009	Gas Distributor 300A
11	20-1030	51350	Tip 50A
	20-1031	51351	Tip 100A
	20-1032	51352	Tip 150A
	20-1033	51353	Tip 225A
	20-1034	51354	Tip 300A
12	20-1002	60396	Shield Cup Body
	20-1029	60397	Shield Cup Body, Underwater (Merlin 6000 only)
13	20-1003	51990	End Cup 50A
	20-1004	51991	End Cup 100-225A
	20-1005	51992	End Cup 300A
	20-1006	51993	End Cup, Underwater, 100-300A
	20-1007	TD201007	End Cup, Non-Conductive
	20-1028	TD201028	End Cup, Underwater (Merlin 6000 only)

Maximizer 300 Merlin 6000 GST

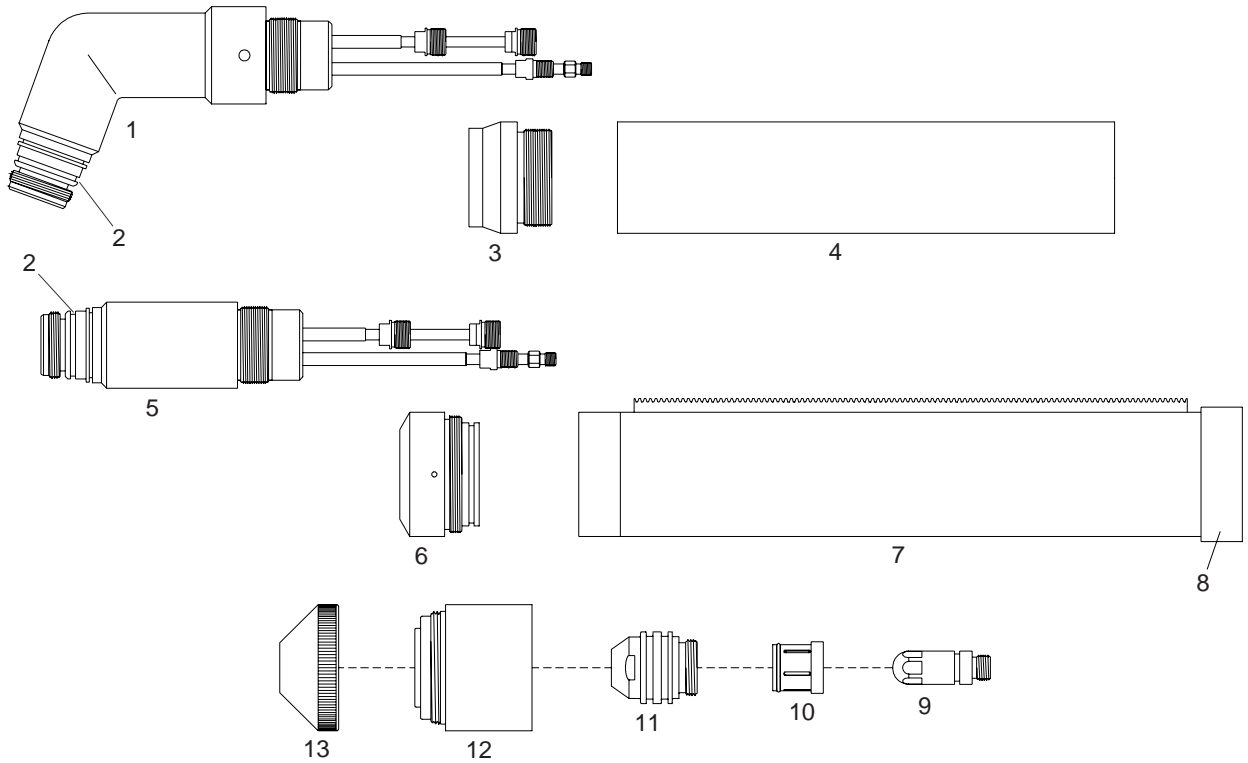

Item	Ref.	Code	Description
1	9-6457	TD96457	70° Torch Head
N/S	9-6459	TD96459	90° Torch Head
2	8-0538	TD80538	O-Ring (10 pcs.)
3	9-6767	TD96767	Adaptor
4	9-6769	TD96769	Mounting Tube
5	9-6410	TD96410	180° Torch Head
6	8-3322	TD83322	Adaptor
7	9-6819	TD96819	Positioning Tube
8	8-6522	TD86522	EndCap
9	20-1010	TD201010	Electrode O2 100-225A
	20-1018	TD201018	Electrode Air 50-225A
	20-1021	TD201021	Electrode Air/O2 300A
	20-1023	TD201023	Electrode N2 50-300A
	20-1025	TD201025	Electrode Ar/H2 100-300A
10	20-0008	TD200008	Gas Distributor 50-225A
	20-1009	TD201009	Gas Distributor 300A
11	20-1030	51350	Tip 50A
	20-1031	51351	Tip 100A
	20-1032	51352	Tip 150A
	20-1033	51353	Tip 225A
	20-1034	51354	Tip 300A
12	20-1002	60396	Shield Cup Body
	20-1029	60397	Shield Cup Body, Underwater
13	20-1003	51990	End Cup 50A
	20-1004	51991	End Cup 100-225A
	20-1005	51992	End Cup 300A
	20-1006	51993	End Cup, Underwater, 100-300A
	20-1007	TD201007	End Cup, Non-Conductive
	20-1028	TD201028	End Cup, Underwater
SQUARE CUT, 50A, O₂-O₂ CONSUMABLES			
9	20-1050	TD201050	Electrode Cutting O2
10	20-0008	TD200008	Gas Distributor, Cutting
11	20-1051	TD201051	Tip Cutting 50A
12	20-1002	60396	Shield Cup Body
13	20-1052	TD201052	Shield Cup End Cup, 50A

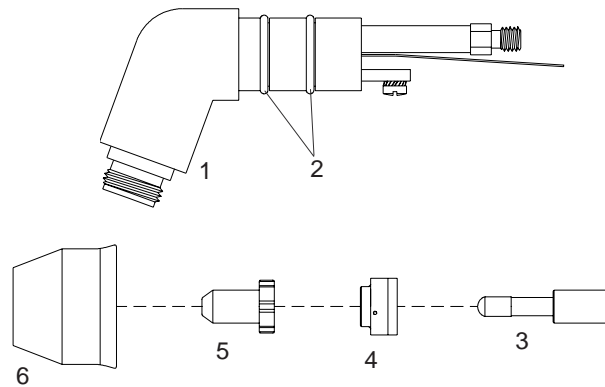
PCH-20 Dynapak 110, Pak 2XT

Item	Ref.	Code	Description
1	8-3220	TD83220	70° Torch Head
2	8-0533	07100.53	O-Ring (20 pcs.)
3	9-6006	52519/D	Electrode
4	8-3233	80052	Gas Distributor
5	8-3218	51284	Tip
6	8-3214	60337	Shield Cup Std.

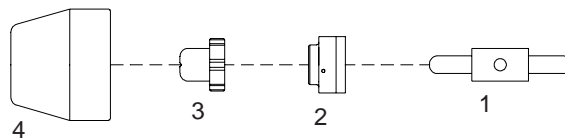
PCH-30 Pak-3

Item	Ref.	Code	Description
1	9-5503	TD95503	Electrode
2	8-3233	80052	Gas Distributor
3	9-5501	TD95501	Tip
4	9-5500	TD95500	Shield Cup Std.

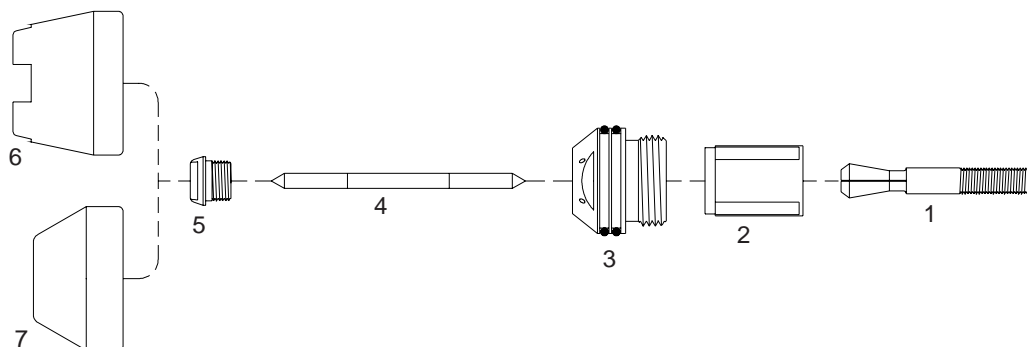
PCH-50 Pak-5

Item	Ref.	Code	Description
1	8-5506	TD85506	Collet
2	8-5510	TD85510	Sleeve
3	8-5520	TD85520	Liner (includes O-Rings)
4	8-5508	TD85508	Electrode
5	8-5507	TD85507	Tip
6	8-5519	TD85519	Shield Cup Crown Ceramic
7	8-5505	TD85505	Shield Cup Std. Ceramic

PCH/M-100 Pak 10XR

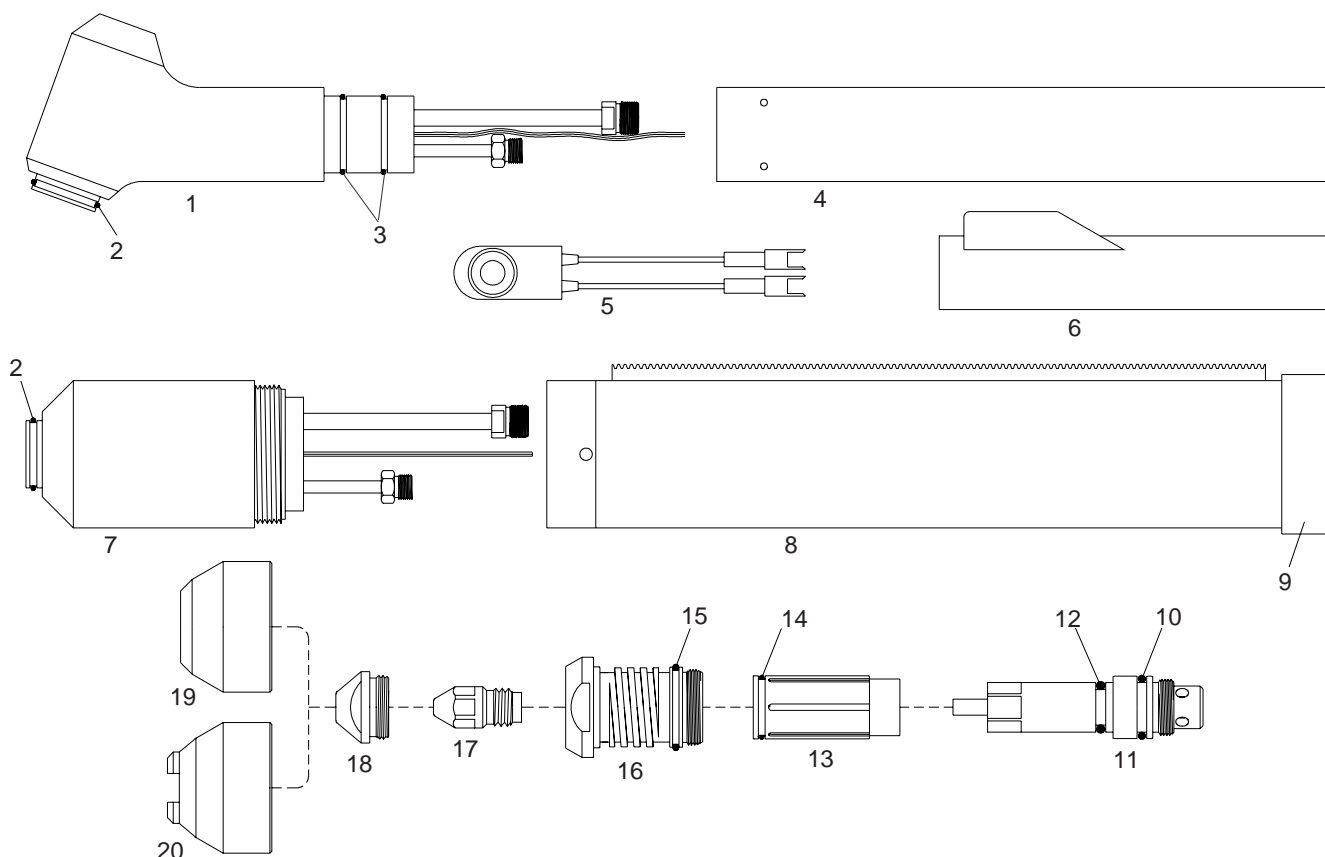

Item	Ref.	Code	Description
N/S	2-2894	07620	Hand torch complete with 25' (7.5 mts) cable
N/S	2-2895	07630	Hand torch complete with 50' (15 mts) cable
N/S	2-2896	07640	Machine torch complete with 25' (7.5 mts) cable and Pinion Assembly
N/S	2-2897	07650	Machine torch complete with 50' (15 mts) cable and Pinion Assembly
1	8-1113	TD81113	70° Torch Head
2	8-0556	TD80556	O-Ring (Shield Cup), (10 pcs.)
3	8-0538	TD80538	O-Ring (Handle), (10 pcs.)
4	8-1114	TD81114	Handle
5	9-5522	TD95522	Switch
6	8-4217	TD84217	Switch Sheath
7	8-1112	TD81112	180° Torch Head
8	8-6521	TD86521	Positioning Tube
9	8-6522	TD86522	End Cap
10	8-1152	01000.60	O-Ring, Electrode Holder, Large (10 pcs.)
11	8-1108	07603	Electrode Holder, w/O-Rings
12	8-1133	07603.42	O-Ring, Electrode Holder, Small (10 pcs.)
13	9-4339	07602	Gas Distributor, w/O-Ring
14	8-1134	07602.41	O-Ring, Gas Distributor (10 pcs.)
15	8-1135	TD81135	O-Ring, Liner (10 pcs.)
16	8-1106	07601	Liner, w/O-Ring
17	9-4340	52525	Electrode
18	9-4343	51125	Tip \varnothing 0.99 - .039 - 35A
	9-4342	51126	Tip \varnothing 1,32 - .052 - 70A
	9-4341	51127	Tip \varnothing 1,50 - .059 - 105A
19	8-1100	80021	Shield Cup - Std.
	9-4345	80020	Shield Cup - Machine
20	8-1101	80022	Shield Cup - Crown
N/S	4-2852	07680	Air and power cable 25' (7.5 mts) - Hand torch
N/S	4-2853	07685	Air and power cable 50' (15 mts) - Hand torch
N/S	4-2854	07690	Air and power cable 25' (7.5 mts) - Machine torch
N/S	4-2855	07695	Air and power cable 50' (15 mts) - Machine torch

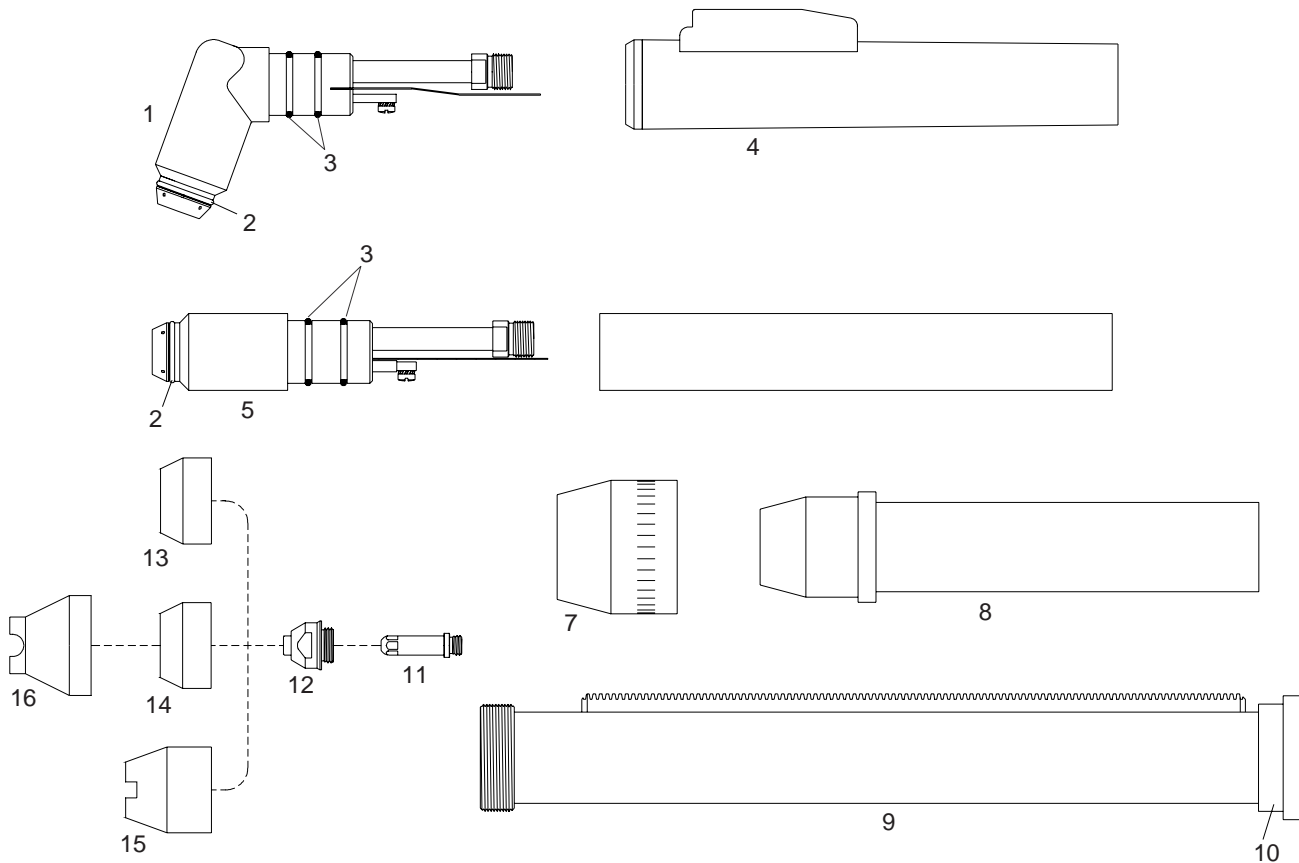
PCH/M-51 4Xi, 6Xi, Pak-3XR, Pak-6XR, Pak-7XR, Pak-5XT, Pak-625XR, Pak-750XR

Item	Ref.	Code	Description
N/S	2-2860	07120	Hand torch complete with 25' (7.5 mts) cable
N/S	2-2861	07130	Hand torch complete with 50' (15 mts) cable
N/S	2-2864	07140	Machine torch complete with 25' (7.5 mts) cable, (with handle item 6)
N/S	2-2865	07150	Machine torch complete with 50' (15 mts) cable, (with handle item 6)
1	9-5635	07100	70° Torch Head
2	8-5525	02000.60	O-Ring (Shield Cup), (20 pcs.)
3	8-0533	07100.53	O-Ring (Handle), (20 pcs.)
4	9-5636E	07103	Handgrip complete with microswitch (incl. 9-5636, 9-5522, 8-1322)
5	9-5634	07110	180° Torch Head
6	9-5637E	07115	Machine handle
7	8-4018	TD84018	Nut
8	9-5637	TD95637	Adaptor
9	8-5005	TD85005	Positioning tube
10	8-4204	TD84204	Endcap
11	9-5633	52517	Electrode, long life
	9-5720	52518	Electrode, 4X1
12	9-5718	51117	Tip 10-40A - Ø 0,96 - .038
	9-5631	51115	Tip 10-60A - Ø 1,10 - .043
	8-3321	51115.12	Tip 65A - Ø 1,20 - .047
	9-5724	51116	Tip Gouging - Ø 2,00 - .078
13	9-5630	80010	Shield Cup Ceramic
14	8-2159	60416	Shield Cup-Phenolic-Std.
15	8-5526	80011	Shield Cup-Crown-Ceramic
16	9-5779	60341	Shield Cup-Crown (fits over 60416)
N/S	4-5030	07180	Air and power cable 25' (7.5 mts) - Hand torch
N/S	4-5031	07185	Air and power cable 50' (15 mts) - Hand torch
N/S	4-5032	07190	Air and power cable 25' (7.5 mts) - Machine torch
N/S	4-5033	07195	Air and power cable 50' (15 mts) - Machine torch

* CIRCLE CUTTING ATTACHMENT : See page #31

PCH/M-52

Pak-5XR*, Pak-6XR*, Pak-7XR, Pak-8XR, Pak-10XR, Pak-625XR*, Pak-750XR*
Pak-1000XR, Pak-1250XR ***=Dual Gas**

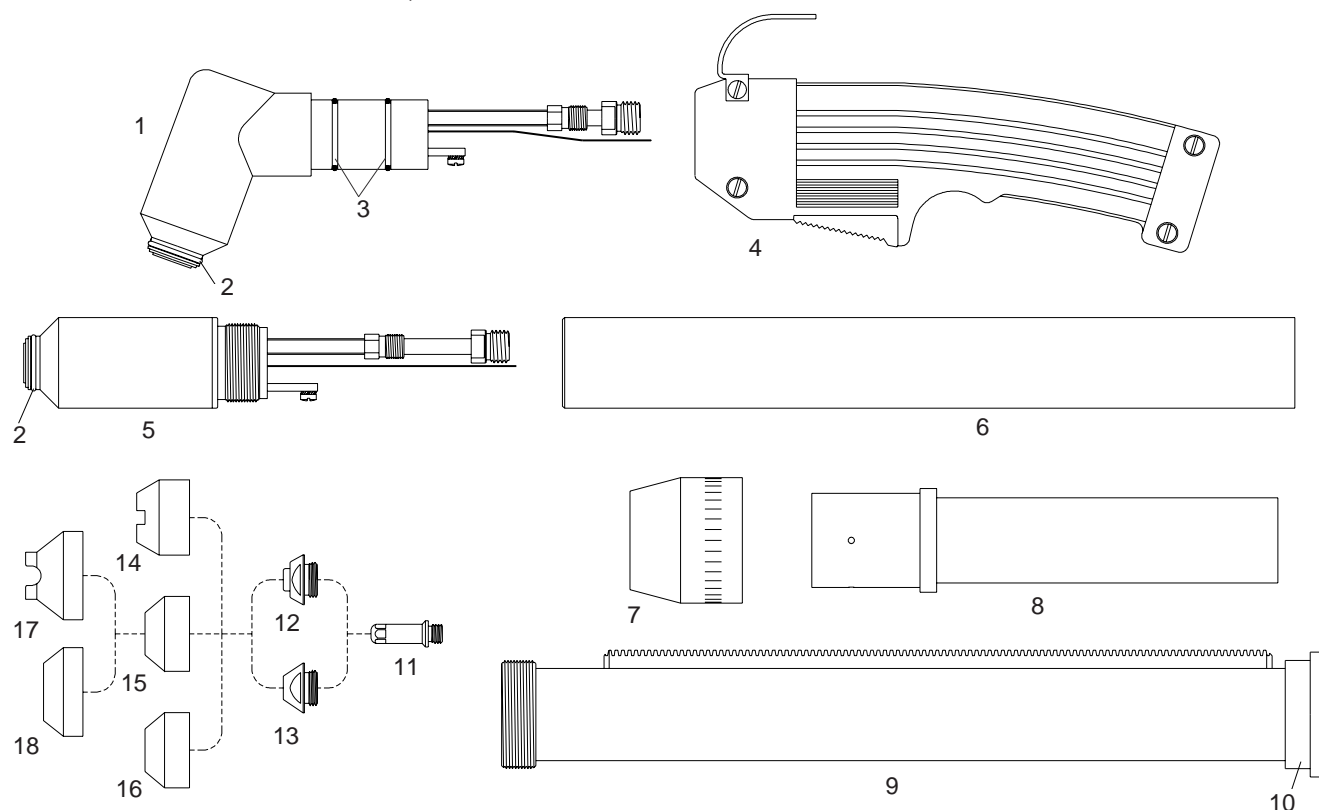

Item	Ref.	Code	Description
N/S	2-2936	07220	Hand torch complete with 25' (7.5 mts) cable
N/S	2-2937	07230	Hand torch complete with 50' (15 mts) cable
N/S	2-2938	07240	Machine torch complete with 25' (7.5 mts) cable, (with handle item 6)
N/S	2-2939	07250	Machine torch complete with 50' (15 mts) cable, (with handle item 6)
1	9-5642	07200	70° Torch Head
2	8-5525	02000.60	O-Ring (Shield Cup), (20 pcs.)
3	8-0536	07200.50	O-Ring (Handle), (20 pcs.)
4	9-5644E	07307	Handgrip complete with microswitch (incl. 9-5644, 9-5522, 8-4216)
5	9-5643	07210	180° Torch Head
6	9-7833	07215	Machine handle
7	8-4018	TD84018	Nut
8	9-1901	TD91901	Adaptor
9	8-5005	TD85005	Positioning tube
10	8-4204	TD84204	Endcap
11	8-3331	52565	Electrode Air, long life
	9-5619	52565/N	Electrode Air (plated), long life
	9-5711	TD95711	Electrode Multi Gas
12	9-5702	51180	Tip 35A - Ø 0,90 - .035
	9-5618	51181	Tip 45-55A - Ø 1,10 - .043
	9-5707	51185	Tip 60-70A - Ø 1,20 - .047
	9-5782	51185.13	Tip 80A - Ø 1,32 - .052
	9-5708	51186	Tip 105A - Ø 1,50 - .059
13	8-5129	TD85129	Tip Gouging
	9-5709	TD95709	Tip Gouging 70A - Ø 1,99 - .078
	9-5710	TD95710	Tip Gouging 105A - Ø 2,36 - .093
	9-5713	51188	Tip Gouging 105A - Ø 2,87 - .113
14	9-5694	80017	Shield Cup-Crown Ceramic
15	9-5781	60418	Shield Cup Phenolic Std.
16	9-5617	80015	Shield Cup Std. Ceramic
17	9-5780	60342	Shield Cup-Crown (fits over 60418)
18	9-5799	60336	Shield Cup (fits over 60418)
N/S	4-5034	07280	Air and power cable 25' (7.5 mts) - Hand torch
N/S	4-5035	07285	Air and power cable 50' (15 mts) - Hand torch
N/S	4-5036	07290	Air and power cable 25' (7.5 mts) - Machine torch
N/S	4-5037	07295	Air and power cable 50' (15 mts) - Machine torch

* CIRCLE CUTTING ATTACHMENT : See page #31

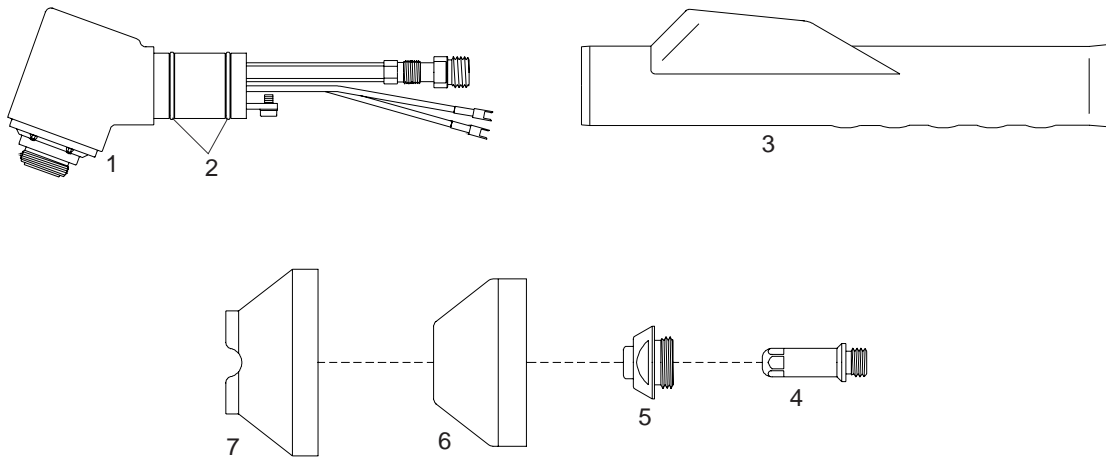
PCH-52P Pak 1250XR

Item	Ref.	Code	Description
1	9-6358	TD96358	70° Torch Head
2	8-0536	07200.50	O-Ring (20 pcs.)
3	9-5644E	07107	Handgrip complete with microswitch (incl. 9-5644, 9-5522, 8-4216)
4	9-5619	52565/N	Electrode Air (plated), long life
	9-5711	TD95711	Electrode Multi Gas
5	9-5702	51180	Tip 35A - Ø 0,90 - .035
	9-5707	51185	Tip 70A - Ø 1,20 - .047
	9-5708	51186	Tip 105A - Ø 1,50 - .059
6	9-6355	TD96355	Shield Cup Std.
7	9-6357	TD96357	Shield Cup Standoff Crown (fits over TD96355)

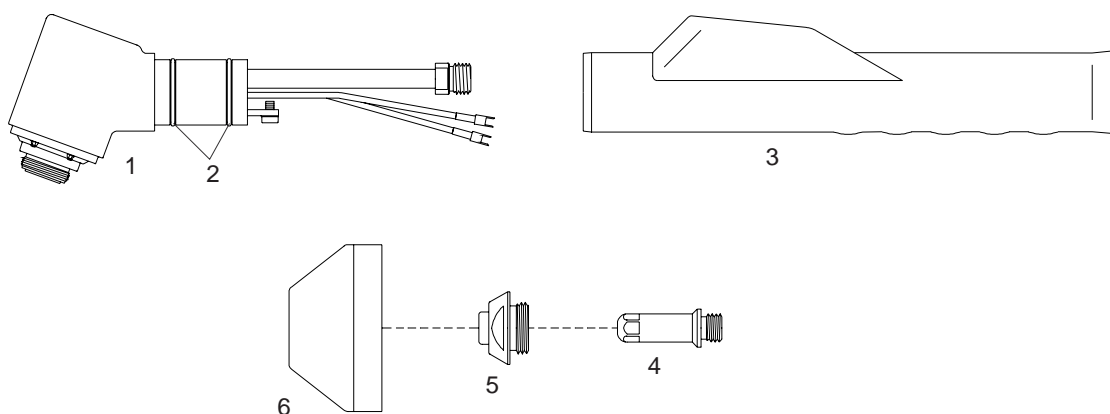
PCH-53P Pak Master 100

Item	Ref.	Code	Description
1	9-6370	TD96370	70° Torch Head
2	8-0536	07200.50	O-Ring (20 pcs.)
3	9-5644E	07107	Handgrip complete with microswitch (incl. 9-5644, 9-5522, 8-4216)
4	9-5898	TD95898	Electrode Air
5	9-5897	TD95897	Tip 70A Air
6	9-6355	TD96355	Shield Cup Std.

PCH/M-53 Pak Master 100

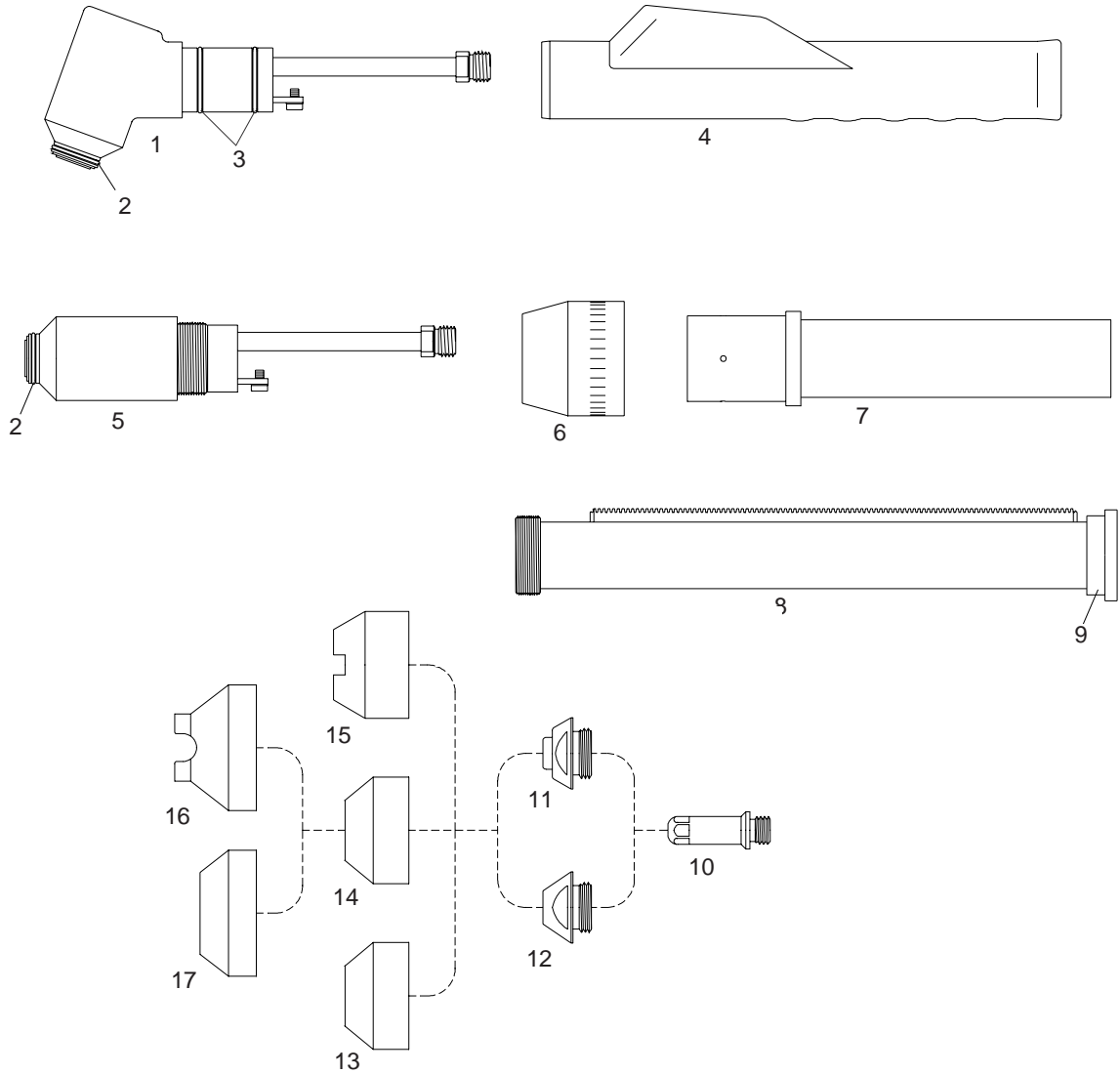

Item	Ref.	Code	Description
1	9-6170	TD96170	70° Torch Head
2	8-5525	02000.60	O-Ring (Shield Cup), (20 pcs.)
3	8-0536	07200.50	O-Ring (Handle), (20 pcs.)
4	9-5644E	07107	Handgrip complete with microswitch (incl. 9-5644, 9-5522, 8-4216)
5	9-6180	TD96180	180° Torch Head
6	8-4018	TD84018	Nut
7	9-1901	TD91901	Adaptor
8	8-5005	TD85005	Positioning tube
9	8-4204	TD84204	Endcap
10	9-5898	TD95898	Electrode Air
11	9-5897	TD95897	Tip 70A
12	9-5709	TD95709	Tip Gouging 70A - Ø 1,99 - .078
13	9-5617	80015	Shield Cup Std. Ceramic
14	9-5781	60418	Shield Cup Phenolic Std.
15	9-5694	80017	Shield Cup-Crown Ceramic
16	9-5780	60342	Shield Cup-Crown (fits over 60418)
17	9-5799	60336	Shield Cup (fits over 60418)

* CIRCLE CUTTING ATTACHMENT : See page #31

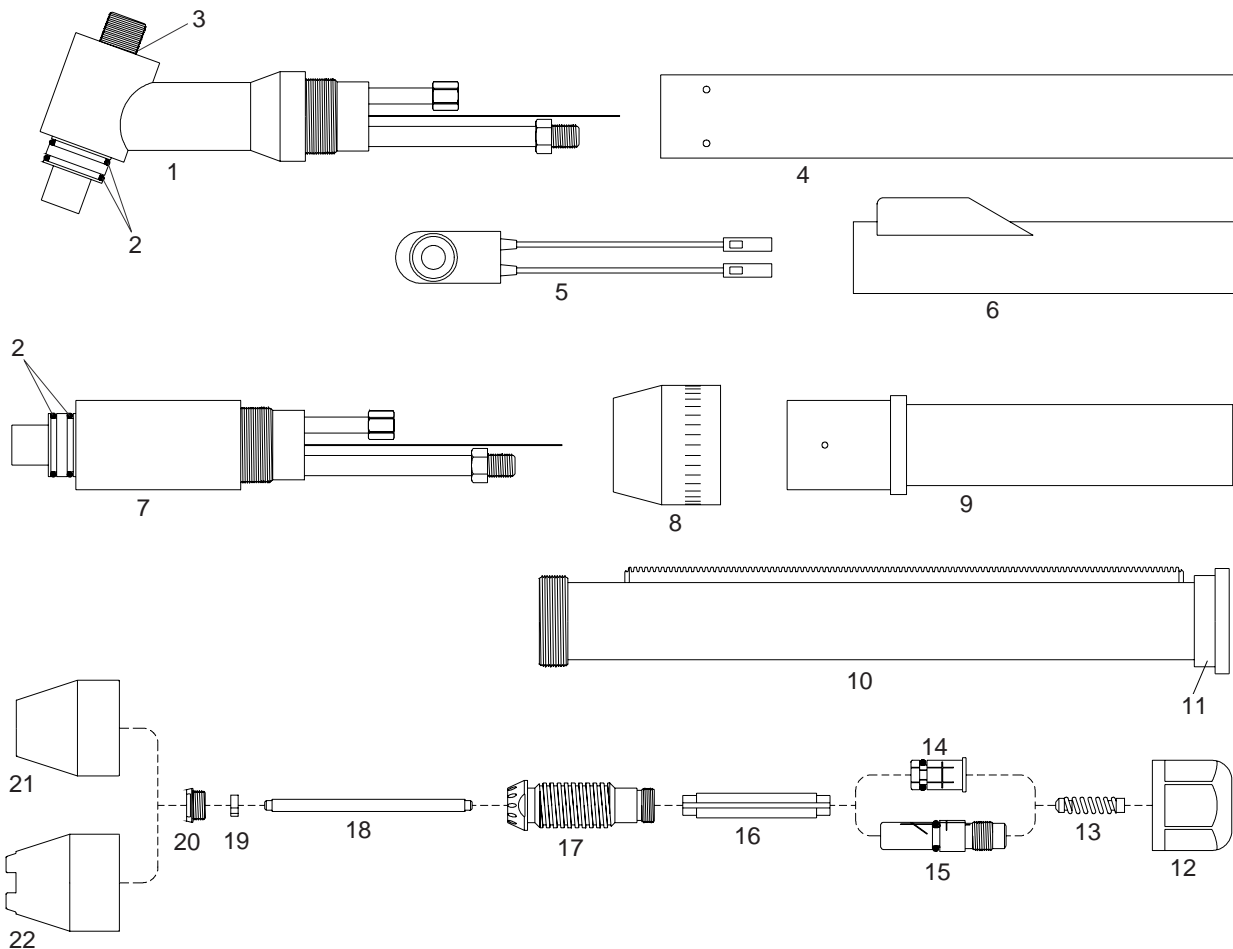
PCH/M-4B(T) Pak-5 (Mech), Pak-10, Pak-10XR (Mech)

Item	Ref.	Code	Description
1	8-4160	TD84160	70° Torch Head
N/S	8-4161	TD84161	90° Torch Head
2	8-0554	TD80554	O-Ring (Shield Cup), (10 pcs.)
3	8-0530	TD80530	O-Ring (Back Cup), (10 pcs.)
4	8-5007	TD85007	Handle
5	8-4218	TD84218	Switch
6	8-4216	TD84216	Switch Sheath
7	8-4196	TD84196	180° Torch Head
8	8-4018	TD84018	Nut
9	9-1901	TD91901	Adaptor
10	8-5005	TD85005	Mounting Tube
11	8-4204	TD84204	End Cap
12	8-4158	TD84158	Back Cap
13	8-4050	TD84050	Spring
14	8-4156	TD84156	Collet Std.
15	8-4197	TD84197	Collet (4BT only)
16	8-4182	TD84182	Sleeve
17	8-4154	TD84154	Liner
18	8-4073	TD84073	Electrode
19	9-2421	TD92421	Gas Distributor
20	8-4153	TD84153	Tip Lo-Amp .059
	8-4189	TD84189	Tip Lo-Amp Std. .030 (4BT/5)
	8-4211	TD84211	Tip Std. .046 (4BT/5)
21	8-4088	TD84088	Shield Cup Std. Ceramic
22	8-4213	TD84213	Shield Cup Crown Ceramic

PCH/M-6B Pak-44, Pak-45

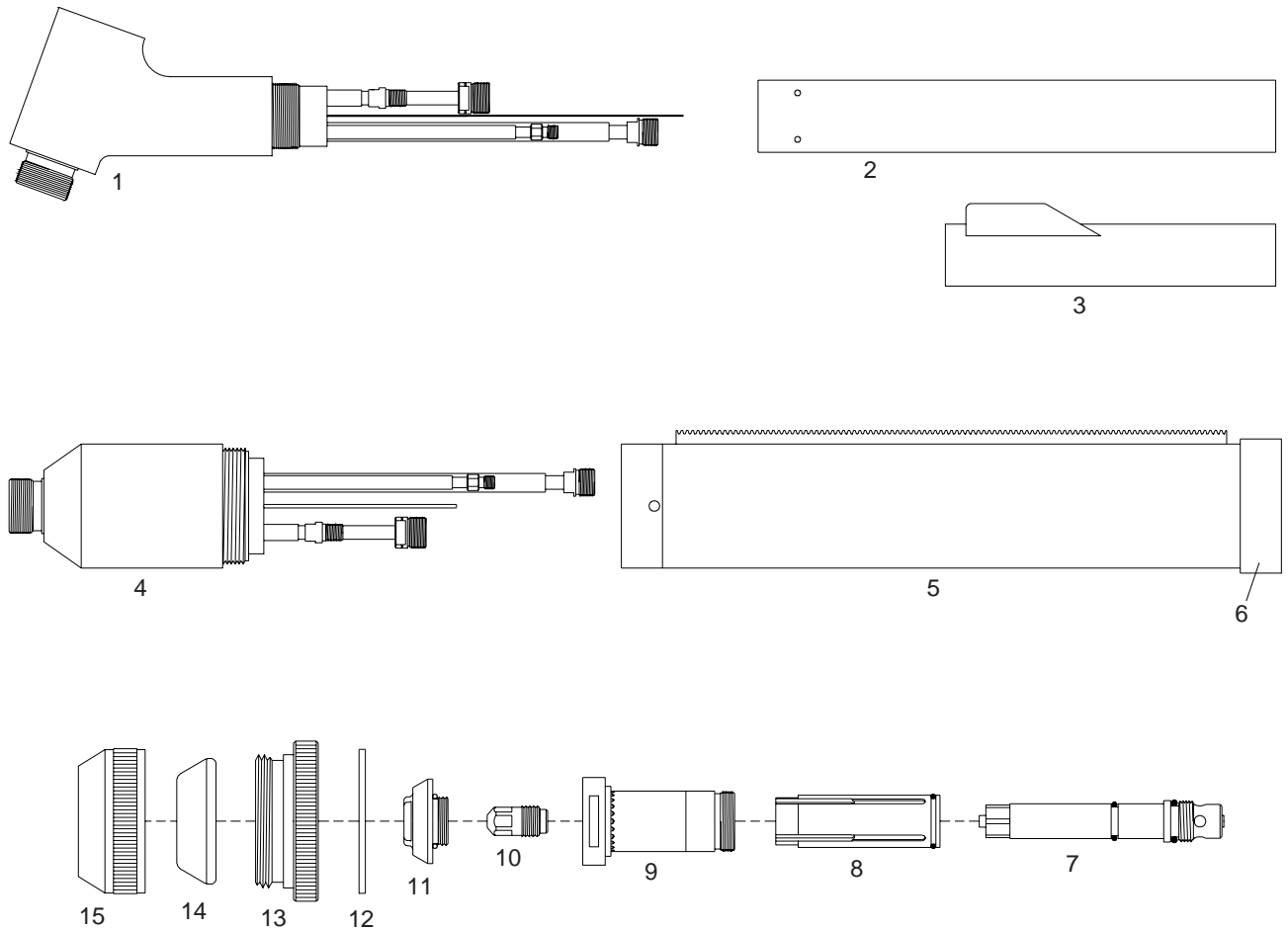

Item	Ref.	Code	Description
1	8-6583	TD86583	70° Torch Head
N/S	8-6584	TD86584	90° Torch Head
2	8-6519	TD86519	Handle
3	8-6564	TD86564	Switch/Sheath/Nomex
4	8-6577	TD86577	180° Torch Head
5	8-6521	TD86521	Positioning Tube
6	8-6522	TD86522	EndCap
7	8-6615	TD86615	Electrode Holder
8	8-6569	TD86569	Gas Distributor
9	8-6571	TD86571	Liner
10	8-6578	TD86578	Electrode Gen Purpose
	8-6586	TD86586	Electrode Lo-Amp
11	8-6580	51190	Tip 100A .067 w/O-rings
	8-6648	51191	Tip 150A .076 w/O-rings
	8-6575	51192	Tip 200A .093 w/O-rings
	8-6582	51193	Tip 300A .113 w/O-rings
	8-6572	51194	Tip 400A .125 w/O-rings
12	8-6512	TD86512	Gasket
13	8-6581	TD86581	Outer Insulator
14	8-6514	80034	End Piece
15	8-6515	TD86515	EndCap

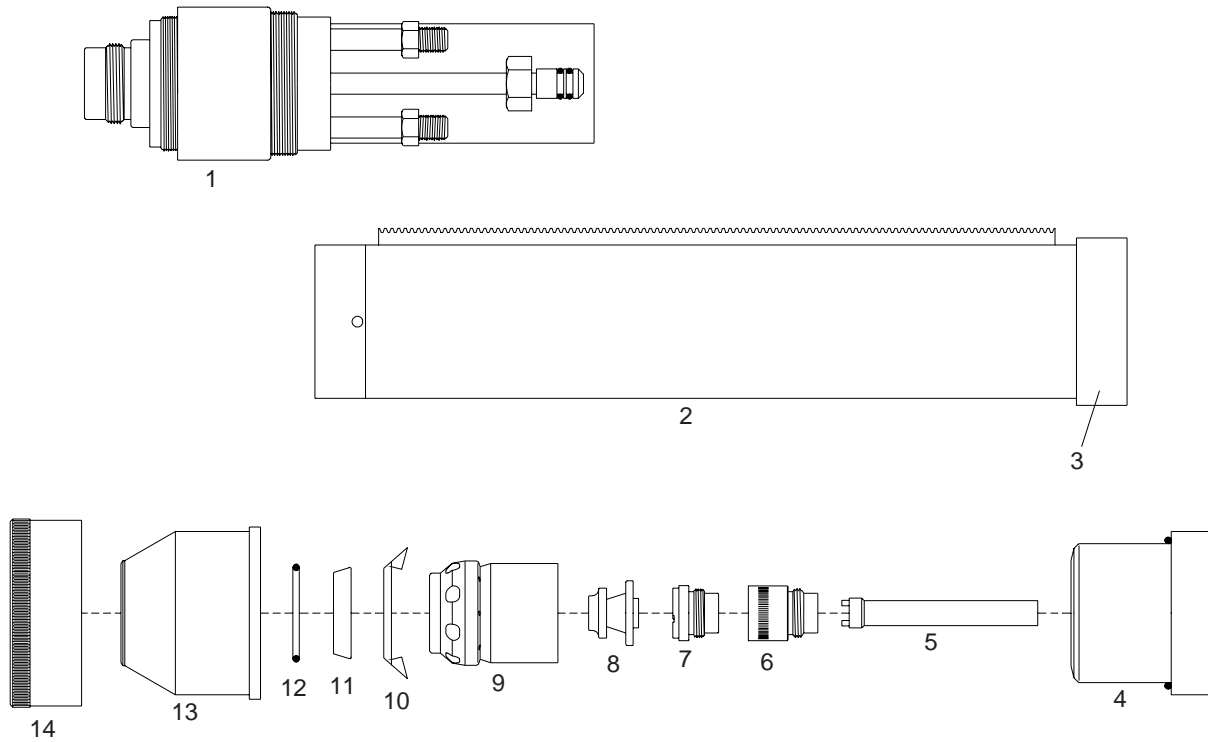
M-200 CC-65, CC-66, TA-500, TAC-500

Item	Ref.	Code	Description
1	8-6054	TD86054	Torch Head
2	9-1720	TD91720	Positioning Tube
3	8-6522	TD86522	End Cap
4	8-6060	TD86060	Outer Insulator
5	9-1640	TD91640	Coolant Tube
6	9-1642	TD91642	Electrode Seat
7	9-1662	TD91662	Electrode 1000A
	9-2841	TD92841	Electrode Rev Swirl
8	9-1641	TD91641	Electrode 500A
	8-6042	TD86042	Tip 250A
	8-6043	TD86043	Tip 350A
	8-6044	TD86044	Tip 500A
	8-6045	TD86045	Tip 750A
	8-6046	TD86046	Tip 1000A
	8-6068	TD86068	Tip 1000A Heavy Duty
	8-6047	TD86047	Tip 500A Gouging
9	9-2210	TD92210	Inner Tip Retainer
10	9-2451	TD92451	Coolant Baffle
11	8-6006	TD86006	End Piece-Water Shield
	8-0607	TD80607	End Piece-Gas Shield
	8-6029	TD86029	End Piece-Ar/H2 Secondary
12	8-0563	TD80563	O-Ring (10 pcs)
13	8-6057	TD86057	End Cap-Heavy Duty
	8-6077	TD86077	End Cap-Underwater
	8-6056	TD86056	End Cap
14	8-6059	TD86059	Collar

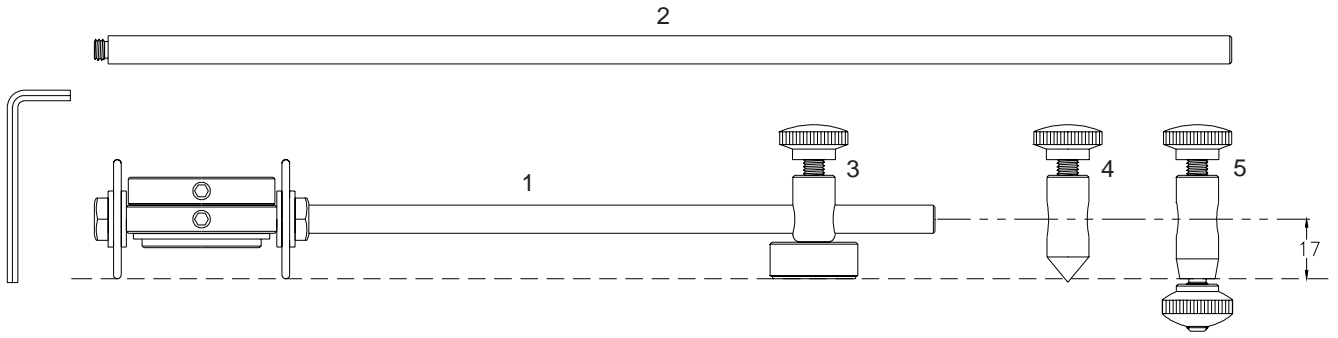

Item	Code	Description
	51859	Circle cutting attachment for PCH-52, PCH-53
	51815	Cutting guide PCH-52, PCH-53
	51846	Circle cutting attachment for PCH-10, PCH-25, PCH-25/38, PCH-26, PCH-28, PCH-35, PCH-40
	51803	Cutting guide PCH-10, PCH-25, PCH-25/38, PCH-26, PCH-28, PCH-35, PCH-40
	51862	Circle cutting attachment for PCH-120
	51822	Cutting guide PCH-120
1	51820	Radius bar mm. 250
2	51821	Radius bar mm. 400
3	51826	Magnetic base assembly
4	51827	Free centering straight pin
5	51828	Straight locking pin

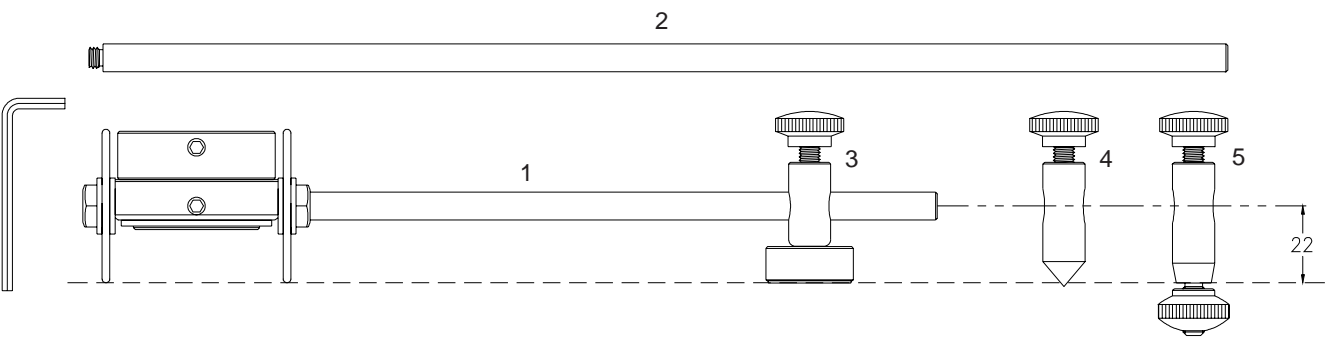

Item	Code	Description
	51857	Circle cutting attachment for PCH-51
	51813	Cutting guide for PCH-51
1	51820	Radius bar mm. 250
2	51821	Radius bar mm. 400
3	51831	Magnetic base assembly
4	51832	Free centering straight pin
5	51833	Straight locking pin